

Bock Compressors for Mobile Applications

Vehicle compressors for bus-, railway air-conditioning and transport refrigeration

In touch with our customers

GEA Refrigeration Technologies: Your partner for low temperatures

GEA Refrigeration Technologies, part of the internationally active GEA Group, is a synonym for industrial refrigeration technology. Since the end of the 19th century, it has been our business to cool processes and products, and to control the temperature of goods in transport.

You will find our solutions in the food and beverage sector; in the petrochemical, chemical, and pharmaceutical industries; on fishing ships; in natural gas liquefaction; in infrastructure facilities; and in ice factories. We are also at the top with know-how when it comes to refrigeration at leisure facilities. After all, we have been excited about refrigeration for decades now. As a result, our staff enthusiastically goes about its development and production projects – to include preventive and remedial maintenance of your refrigeration systems.

This enthusiasm is highly apparent in the daily work of all companies in our Segment. Whether it's complete systems or individual valves: we have the experience in every section of our company to optimally design, manufacture, and install refrigeration systems. And to take full advantage of this experience, we not only carry out development in our own company: we also manufacture, assemble, and test the core components. A chain is, after all, only as strong as its weakest link: and this also applies equally well to refrigeration technology, cooling processes, and cooling chains.

This makes it all the more important that you have a partner – in GEA Refrigeration Technologies – that has learned to master refrigeration from A to Z. And all of this since 1896, when Willem Grasso founded his refrigeration division. From this history of GEA Refrigeration Technologies, you will profit in the form of technical expertise and top sector know-how.

But we all live in the present and think about the future. We ponder a future in which more and more processes need energy around the world, and fewer natural resources are available. As a result, we have taken it as our goal to create solutions that are not only long-life and cost-effective, but also energy-saving and environment-protecting. We feel obligated to sustainability in many respects. Our objective is to produce longlife and material-saving products over the long run – as well as products that use environmentally benign refrigerants. And we aim to produce efficiently. But our responsibility does not end at the factory gate. As a result, we take great pains to ensure that our systems are energy-efficient and that they protect the climate. With GEA Refrigeration Technologies, you can also count on optimal economy: saving energy indeed means reducing money spent for energy. At the same time, you protect the environment. Thanks to our refrigeration technology, your processes will run more economically and more ecologically. To maintain our standard of living and to assure quality of life for future generations as well. Our claim of combining economy with saving natural resources is reflected in all components of our company, such as the following: compressors, chillers, heat pumps, ice machines, fittings and valves, control systems, and many, many more. You can find proof of the above throughout the world. Our international corporate network – and above all our reference projects – are spread all over the globe.



Characteristics vehicle compressors FK I	1
Vehicle compressors FK for bus- and railway air-conditioning N, K I	2
Vehicle compressors FK for transport refrigeration TK I	3
Characteristics semi-hermetic compressors HG I	4
Semi-hermetic compressors HG for bus- and railway air-conditioning I	5
Semi-hermetic compressors HG for R407C up to 35 bar I	6
Service - Made by GEA Bock I	7

Disclaimer

This brochure has been produced for you with the greatest of care. Nevertheless it is not possible to rule out mistakes completely. In such cases we cannot assume any liability. The contents correspond to the status on going to print. Illustrations may include optional equipment. Deviations cannot be ruled out because of the ongoing development process of our products.

The details are provided as unbinding general information and cannot substitute detailed, individual consultation. Reprints even only of excerpts only allowed with the explicit approval of GEA Bock GmbH.

© GEA Bock GmbH 2014



GEA Bock - More than a compressor

Over 80 years ago, when the refrigeration and air-conditioning industry was still in its infancy, our company's founder, Wilhelm Bock, had a vision: He wanted to build first-class and reliable refrigeration machines. In the following decades Bock developed into one of the world's leading manufacturers of refrigeration and air-conditioning compressors.

As part of the GEA Group AG, GEA Bock offers the right compressor for refrigeration and air conditioning in all commercial, industrial, rail, bus and transport sectors.

Besides the vehicle compressors of the FK-series for classical Diesel engines, new technologies have moved into GEA Bock's focus. For example special compressors for the use in hybrid systems.

These electric powered, semi-hermetic compressors offer numerous advantages for mobile applications. The aluminum version is for example about 40 % lighter than comparable standard compressors and contributes to the innovative lightweight construction of vehicles.

Based on the current semi-hermetic program there is now a compressor series available for the use with the refrigerant R407C with expanded fields of application.

No matter what your application is – GEA Bock offers you the ideal compressor for your individual demand.

Be inspired. By our new products, our established product series and the entire passion that goes into each of our products.



Semi-hermetic compressors HG (HA)

The GEA Bock HG (Hermetic Gas-cooled) range of semi-hermetic compressors offers traditional suction gas-cooled compressor state of the art technology. These compressors of the highest quality standard excel in their running comfort, easy maintenance, efficiency and reliability. Suitable as standard for conventional or chlorine-free HFC refrigerants.

The HA (Hermetic Air-cooled) range, specially engineered by GEA Bock, is available for deep-freezing applications, in particular for use with the refrigerants R22 and R404A.

- Single-stage
- CO₂ compressors subcritical
- CO₂ compressors transcritical
- R134a compressors
- R407C compressor
- ATEX compressors
- HC compressors
- Aluminium compressors
- 2-pole compressors
- Two-stage compressors
- Duplex compressors
- Compressor units with receiver
- Condenser units air-cooled



Vehicle compressors FK

GEA Bock vehicle compressors of the FK range are the result of many years of experience in the domain of mobile cooling systems.

The unsurpassed light, compact, robust design and wide r.p.m. range are only some of the outstanding features of this unique product range of two, four and six cylinder compressors.

A wide variety of designs can be tailored to suit individual requirements.

The so-called K version is a special innovation with a unique valve plate system for maximum requirements in bus and coach air-conditioning systems.

- Compressors for bus and train air-conditioning
- Compressors for transport refrigeration and other applications



Open type compressors F

The F model series provides modern open type compressors for separate drive systems (using V belts or direct couplings). The power transmission occurs via an elastic flexible shaft coupling.

Virtually all drive capacity requirements can be met.

Very compact compressor design, robust and easy to handle. Oil pump lubrication as standard.

- F compressors
- F NH₃ compressors
- Compressor units for direct drive
- NH₃ compressor units for direct drive



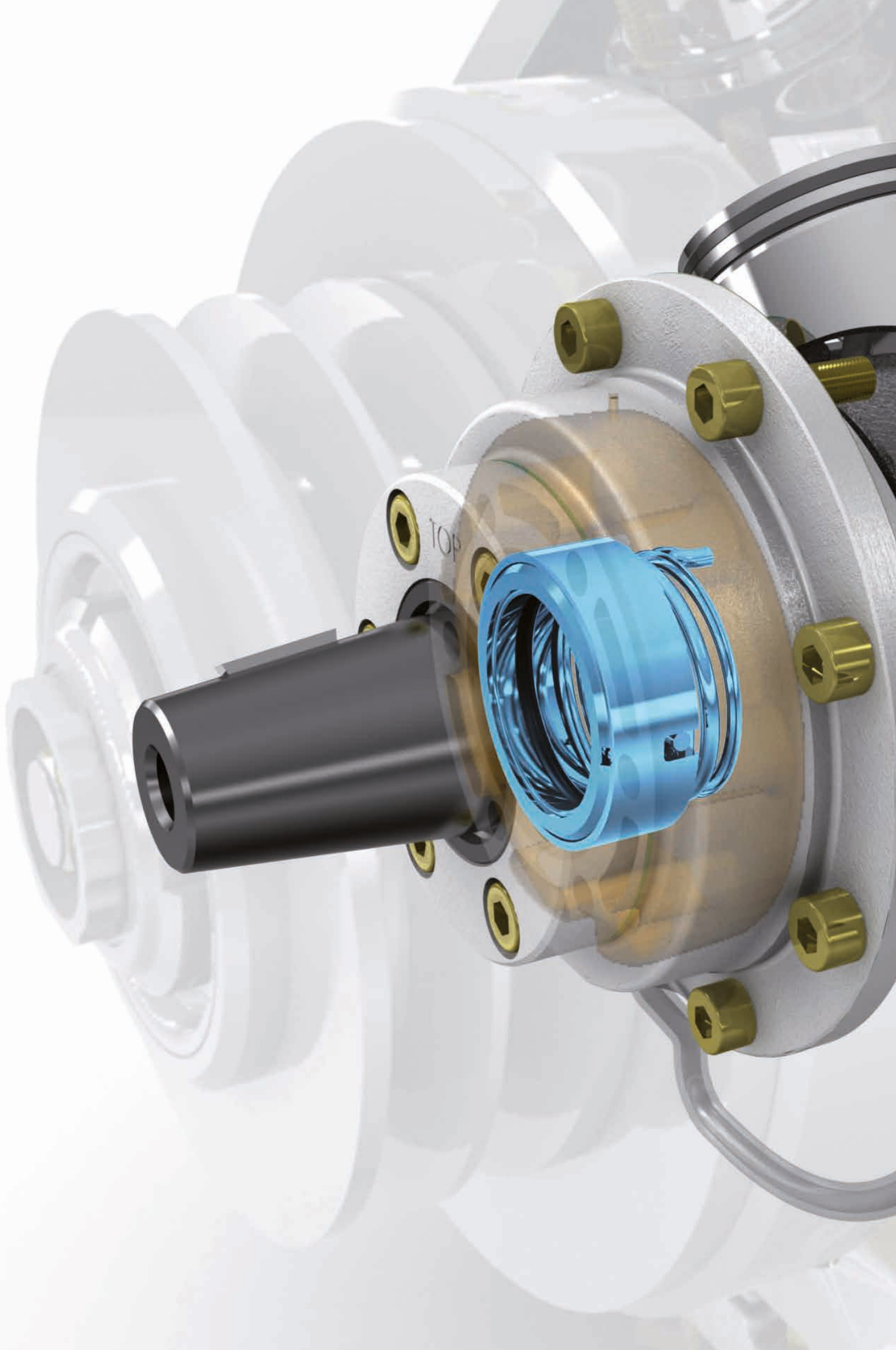



The difference is in the detail -
Characteristics Bock FK
Vehicle compressors

Special features

Open type 2-, 4- and 6-cylinder compressors in full-aluminium lightweight construction

Whether in bus- or railway air-conditioning, transport refrigeration or other applications of mobile cooling - Bock FK compressors are specialists around the world.

- Unsurpassed light and compact design
- Highly robust design
- Wide speed range
- Efficient operating performance
- Universal application

Three design variations are available for different areas of application:

- For air-conditioning - the K Design
- For air-conditioning or normal cooling - the N Design
- For deep freezing - the TK Design

The differences are mostly associated with the valve plate version which is adapted to each application range where operational safety and efficiency are concerned.

Additionally we have different solutions for the flexible adaptation of the compressors to your individual requirements.

Talk to us. Our competent team will be pleased to advise you.

Low-wearing long-lived mechanism



- Solid construction and design
- Classic crankshaft construction with hardened surface
- Double-sided roller bearing mounting design for maximum radial forces
- Aluminium pistons with two-ring assembly
- Aluminium connection rod in divided, screwed design
- Quiet with low vibrations
- Four cylinder construction from 385 cm³
- Six cylinder already from 662 cm³
- Minimum oscillating mass, connecting rods and pistons made out of aluminium
- Dynamic mass balance of the whole drive-mechanism
- High volume pressure area to dampen pulsations

Reliable and safe oil supply



- Self-contained lubrication through an internal rotor pump high performance, independent of rotating direction, compact
- Oil overpressure valve to regulate the oil pressure
- High volume oil sump
- Two sight glasses for checking the oil level (FK40/50), (FK30 one sight glass)

The K Design

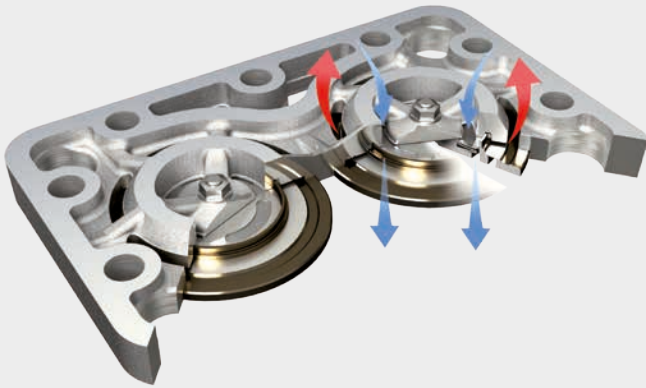

- A special GEA Bock innovation. The unique valve plate system for highest standards - specially developed for bus air-conditioning systems.
- Service valves made out of high quality, impact resistant spring steel. Extremely robust and reliable, not only at constant variations in speed and in pressure, but also where there are liquids. The base plate of this systems is made - of aluminium. The valves are constructed as ring-fin packages and are guided loosely. This means that they are neither exposed to lateral nor torsional powers and thanks to their special construction they cannot fall into the cylinder area or hit the the piston head. The no compromise solution for mobile air conditioning.
- Highest safety and efficiency in all areas of application

1

2

3

4

5

6

7

8

The N Design

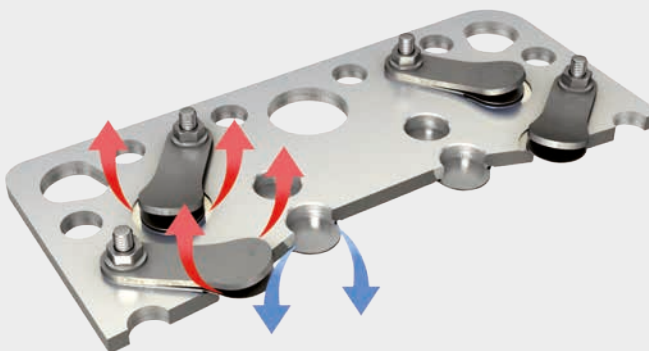

- The cost-effective alternative to the K Design.
- The universal valve plate system. Suitable for both air-conditioning in buses and for other applications. The base plate is designed in steel. The valve units N and TK design are structured as one-sided fixed tongue fins which makes them form a simple and cost-effective construction. In comparison to the K design, the valves are exposed to lateral and torsional powers, which means that the load carrying ability decreases in particular in air-conditioning where there is fluctuating speed or liquid influence.

The TK Design



- A special variant for deep freezing.
- Build on the N valve plate basic concept with additional measures to optimise the charging efficiency at low evaporation temperatures. The piston heads have suction fin contour grooves, which further reduces the dead space and leads to increased performance in the deep-freeze area.

Integrated oil collection system with a large storage volume

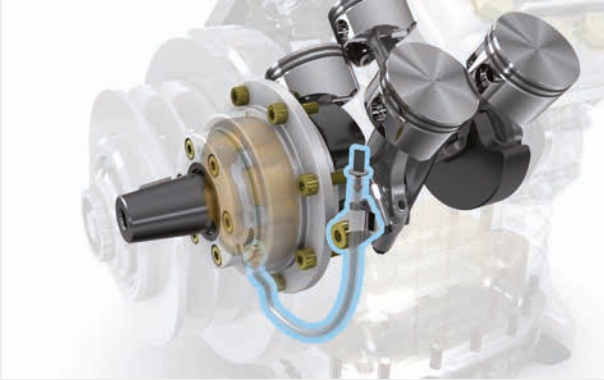

FK30/FK40/FK50:

- Practical drain option through a feely accessible flexible tube
- No dismantling of the clutch necessary

Simply constructed shaft seal

- Tried and tested construction for decades
- Only one O-ring seal, counter ring designed as the screw-on cover
- With oil washing for cooling and lubricating the whole unit
- Easy to change the shaft seal for maintenance purposes

Example:

Shaft seal construction FK40

Integrated oil collection system

Only one O-ring seal

Practical drain-option via freely-accessible flexible tube

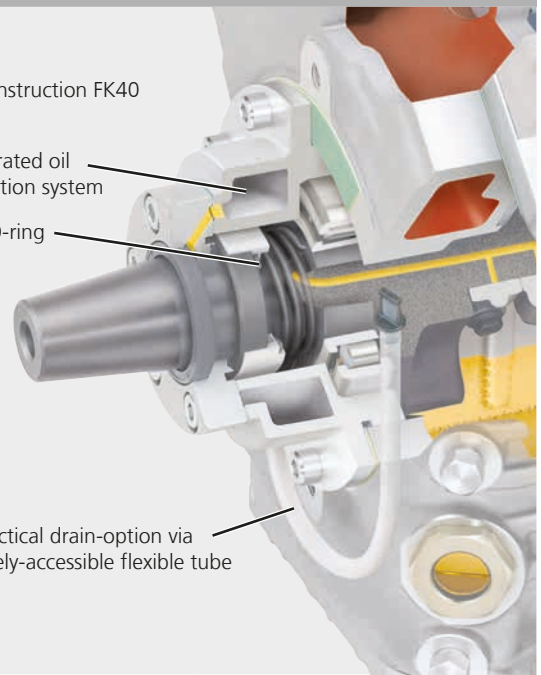

Various drive options

- Conical shaft end for safe force transmission and exact installation of the drive elements
- V-belt drive with electromagnetic clutch or flywheel
- Additional drive types on request

Economic performance regulation (option)

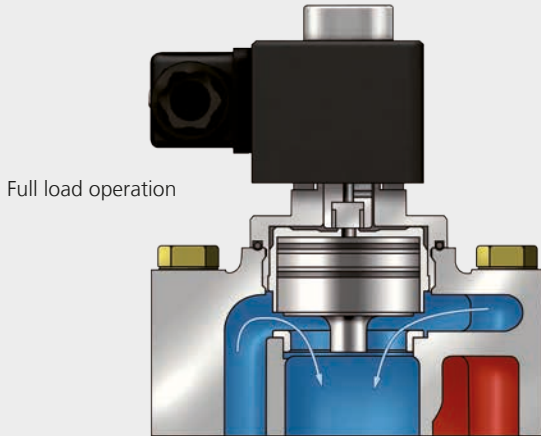

Full load operation

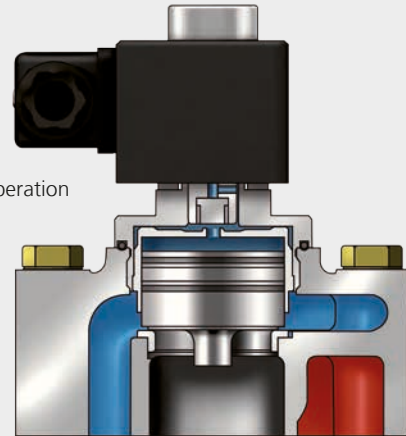

Partial load operation

- Blocking of the intake of a cylinder bank with an electromagnetic pilot valve
- Possible residual capacity:
4-cylinder compressor: 50 % 6-cylinder compressor: 66 %/ 33 %

1
2
3
4
5
6
7
8

Variable connection and fixing options

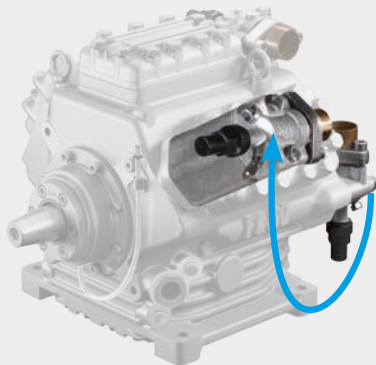

Special design, example:
Suction shut-off valve mounted on cylinderbank with intermediate adapter

- Variable position of the suction shut-off valve (FK30/40/50)
- Rotate options for the suction and discharge shut-off valve
- Fixing options for supplementary attachments



Special design, example:
Suction shut-off valve mounted between the cylinder covers

- More variants for fixing the compressor
- Customer-made designs on request





Vehicle Compressors FK for bus- and railway air-conditioning N, K

At a glance	14
Operating limits and performance data	15
Technical data	21
Dimensions and connections	22
Scope of supply and accessories	28

Type key

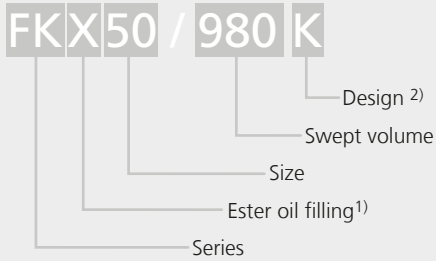

- 1) X - Ester oil filling (HFC refrigerant e.g. R134a, R407C)
- 2) K - specially for air-conditioning
N - for air-conditioning or normal cooling

The current program

...4 model sizes with 14 capacity stages from 10,3 to 84,9 m³/h (1450 rpm)

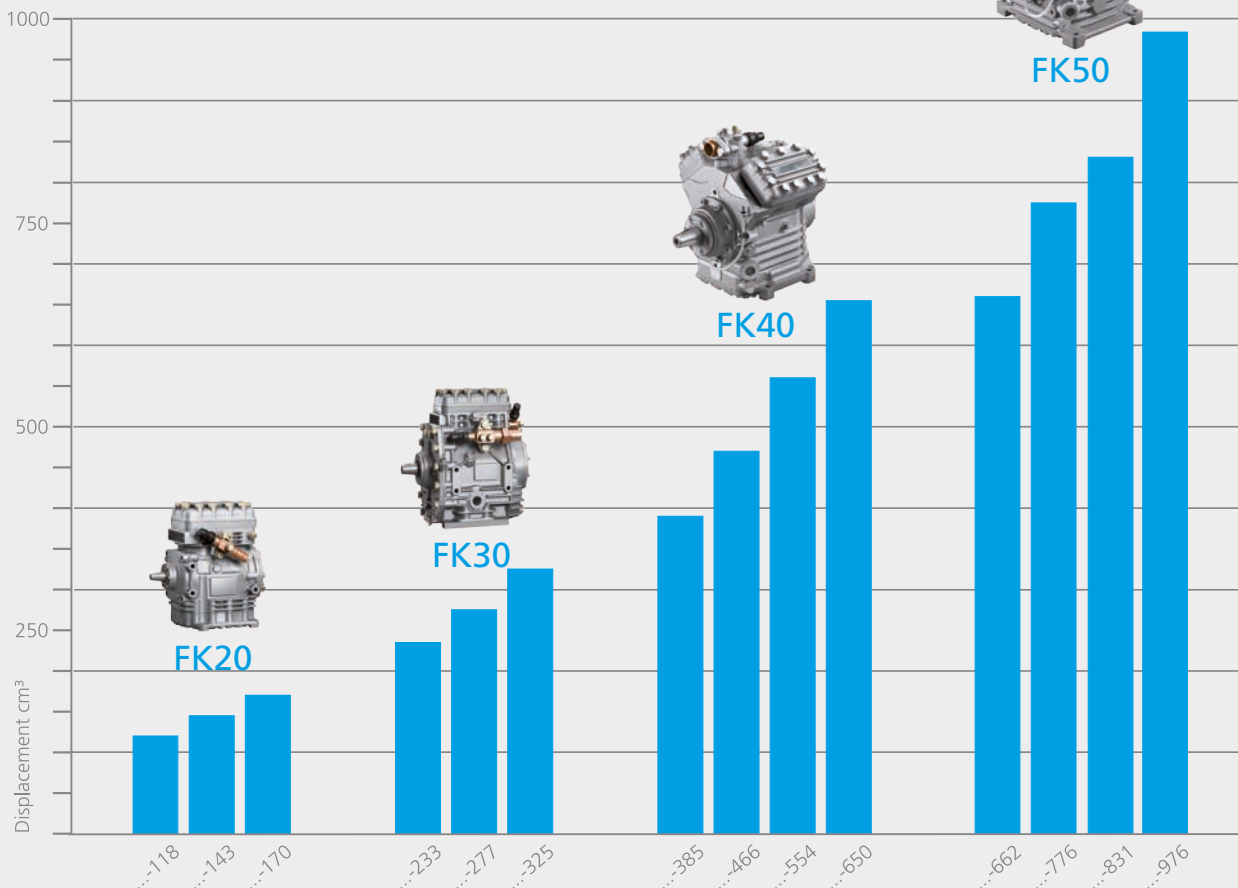

R134a Operating limits

FKX20 / FKX30 / FKX40 / FKX50

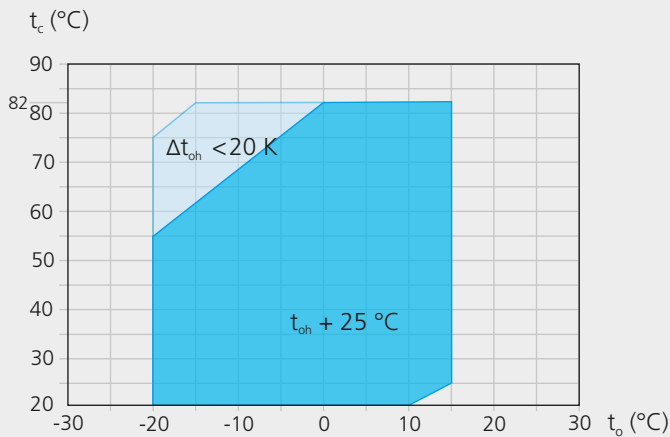

- Unlimited application range
- Reduced suction gas temperature

- t_o Evaporating temperature (°C)
- t_c Condensing temperature (°C)
- Δt_{oh} Suction gas superheat (K)
- t_{oh} Suction gas temperature (°C)

Max. permissible operating pressure (LP/HP)¹⁾: 19/28 bar

¹⁾ LP = low pressure HP = high pressure

Permissible rotation speed:
 N Design: 500 - 3000 rpm
 (max. rotation speed 3500 rpm)
 K Design: 500 - 3500 rpm

R134a Notes

Operating limits

Compressor operation is possible within the limits shown on the application diagrams. Please note the coloured areas. Compressor application limits should not be chosen for design purposes or continuous operation.

Restrictions to the operating limits may occur when using a capacity regulator.

Performance data

Performance specifications for the R134a are based on 25 °C suction gas temperatures without liquid subcooling (FKX50/830 and FKX50/980 on 20 °C suction gas temperature). Compressor speed 1450 rpm. The values can be stated to judge the overall performance at other speed with the help of the calculation factors below. Performance data for other operating points, see GEA Bock software.

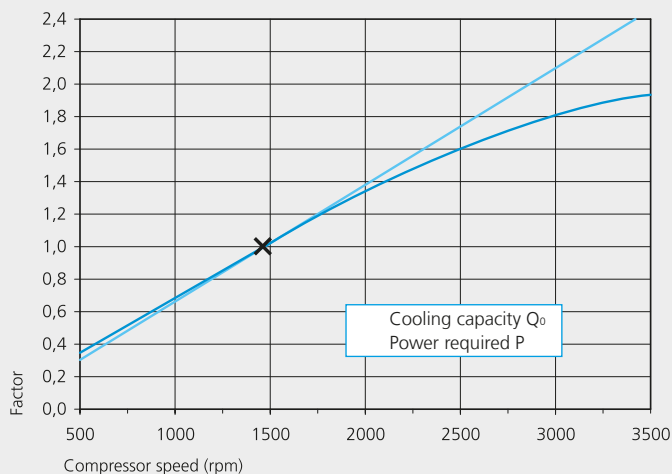

- 1
- 2
- 3
- 4
- 5
- 6
- 7
- 8

R134a		Performance data								1.450 rpm	
Type	Cond. temp. °C		Cooling capacity \dot{Q}_o [W]					Power consumption P [kW]			
			Evaporation temperature °C					-5	-10	-15	
			15	12,5	10	5	0				
FKX20/120 N FKX20/120 K	30	Q	9827	8983	8194	6771	5540	4484	3584	2823	
		P	0,91	0,95	0,99	1,03	1,02	0,99	0,93	0,85	
	40	Q	8789	8020	7302	6009	4895	3940	3129	2443	
		P	1,30	1,31	1,32	1,29	1,24	1,16	1,06	0,96	
	50	Q	7720	7027	6380	5221	4226	3376	2655	2045	
		P	1,65	1,63	1,60	1,52	1,42	1,31	1,18	1,05	
60	Q	6629	6012	5438	4415	3540	2798	2170	1639		
	P	1,95	1,90	1,85	1,72	1,58	1,43	1,27	1,13		
70	Q	5522	4982	4483	3598	2847	2214	1682	1232		
	P	2,20	2,12	2,05	1,88	1,70	1,52	1,35	1,19		
FKX20/145 N FKX20/145 K	30	Q	11890	10870	9915	8193	6704	5425	4336	3416	
		P	1,10	1,15	1,20	1,24	1,24	1,20	1,12	1,03	
	40	Q	10635	9704	8835	7271	5923	4768	3786	2956	
		P	1,58	1,59	1,59	1,56	1,50	1,40	1,29	1,16	
	50	Q	9342	8502	7720	6318	5113	4085	3213	2475	
		P	2,00	1,97	1,94	1,85	1,72	1,58	1,43	1,27	
60	Q	8021	7274	6580	5342	4284	3386	2626	1984		
	P	2,36	2,30	2,23	2,08	1,91	1,73	1,54	1,37		
70	Q	6681	6029	5425	4353	3445	2679	2035	1491		
	P	2,66	2,57	2,47	2,27	2,05	1,84	1,63	1,44		
FKX20/170 N FKX20/170 K	30	Q	14150	12936	11800	9751	7978	6456	5160	4066	
		P	1,31	1,37	1,42	1,48	1,47	1,42	1,34	1,23	
	40	Q	12656	11549	10514	8654	7048	5674	4505	3517	
		P	1,87	1,89	1,90	1,86	1,78	1,67	1,53	1,38	
	50	Q	11117	10118	9188	7519	6085	4861	3823	2945	
		P	2,38	2,35	2,31	2,20	2,05	1,88	1,70	1,51	
60	Q	9545	8657	7831	6357	5098	4029	3125	2361		
	P	2,81	2,74	2,66	2,48	2,27	2,05	1,84	1,62		
70	Q	7951	7175	6456	5181	4100	3189	2422	1775		
	P	3,17	3,06	2,94	2,70	2,44	2,19	1,94	1,72		
FKX30/235 N FKX30/235 K	30	Q	19421	17754	16195	13383	10949	8861	7083	5580	
		P	1,79	1,89	1,96	2,03	2,02	1,95	1,84	1,68	
	40	Q	17370	15850	14431	11877	9674	7787	6183	4827	
		P	2,57	2,60	2,60	2,56	2,45	2,29	2,10	1,89	
	50	Q	15258	13887	12610	10319	8351	6672	5247	4042	
		P	3,26	3,22	3,17	3,01	2,81	2,58	2,33	2,07	
60	Q	13100	11881	10748	8725	6997	5530	4289	3240		
	P	3,86	3,76	3,65	3,40	3,12	2,82	2,52	2,23		
70	Q	10912	9847	8861	7110	5627	4376	3324	2436		
	P	4,35	4,20	4,04	3,71	3,36	3,00	2,67	2,35		
FKX30/275 N FKX30/275 K	30	Q	23112	21129	19273	15927	13031	10545	8429	6641	
		P	2,13	2,24	2,33	2,41	2,41	2,32	2,18	2,00	
	40	Q	20672	18863	17173	14134	11513	9268	7359	5745	
		P	3,06	3,09	3,10	3,04	2,91	2,72	2,50	2,25	
	50	Q	18158	16527	15007	12280	9938	7940	6244	4810	
		P	3,88	3,84	3,77	3,59	3,35	3,07	2,77	2,47	
60	Q	15590	14139	12791	10383	8327	6581	5104	3856		
	P	4,59	4,47	4,34	4,04	3,71	3,35	3,00	2,65		
70	Q	12987	11718	10545	8462	6697	5208	3956	2899		
	P	5,17	5,00	4,81	4,41	3,99	3,57	3,17	2,80		
FKX30/325 N FKX30/325 K	30	Q	27125	24797	22619	18692	15293	12376	9892	7794	
		P	2,50	2,63	2,73	2,83	2,82	2,73	2,56	2,35	
	40	Q	24260	22137	20155	16588	13511	10877	8636	6742	
		P	3,59	3,63	3,63	3,57	3,42	3,20	2,93	2,64	
	50	Q	21311	19396	17612	14412	11664	9319	7329	5646	
		P	4,56	4,50	4,43	4,21	3,93	3,60	3,25	2,90	
60	Q	18297	16594	15012	12186	9773	7723	5990	4525		
	P	5,38	5,25	5,10	4,75	4,35	3,94	3,52	3,11		
70	Q	15241	13753	12376	9931	7859	6112	4643	3402		
	P	6,07	5,87	5,65	5,18	4,69	4,20	3,72	3,29		
FKX40/390 N FKX40/390 K	30	Q	32100	29345	26769	22120	18098	14646	11707	9223	
		P	2,96	3,12	3,23	3,35	3,34	3,23	3,03	2,78	
	40	Q	28711	26198	23852	19631	15990	12872	10221	7979	
		P	4,25	4,29	4,30	4,22	4,04	3,78	3,47	3,12	
	50	Q	25220	22954	20842	17056	13803	11028	8673	6681	
		P	5,39	5,33	5,24	4,98	4,65	4,26	3,85	3,43	
60	Q	21653	19638	17765	14421	11565	9140	7089	5355		
	P	6,37	6,21	6,03	5,62	5,15	4,66	4,16	3,69		
70	Q	18037	16276	14646	11752	9301	7234	5494	4026		
	P	7,19	6,94	6,68	6,13	5,55	4,96	4,41	3,89		

Relating to 25 °C suction gas temperature, without liquid subcooling

 Reduced suction gas temperature

R134a		Performance data								1.450 rpm
Type	Cond. temp. °C	Cooling capacity \dot{Q}_0 [W]					Power consumption P [kW]			
		Evaporating temperature °C								
		15	12,5	10	5	0	-5	-10	-15	
FKX40/470 N FKX40/470 K	30	Q	38841	35508	32390	26765	21899	17722	14165	11160
		P	3,58	3,77	3,91	4,05	4,04	3,91	3,67	3,37
	40	Q	34740	31700	28861	23753	19347	15575	12367	9655
		P	5,15	5,20	5,20	5,11	4,89	4,58	4,20	3,78
	50	Q	30516	27774	25219	20638	16702	13344	10494	8084
		P	6,52	6,45	6,34	6,03	5,63	5,16	4,66	4,15
60	Q	26201	23762	21496	17450	13994	11060	8578	6479	
	P	7,71	7,52	7,30	6,80	6,23	5,64	5,04	4,46	
70	Q	21825	19693	17721	14220	11254	8753	6648	4871	
	P	8,70	8,40	8,08	7,41	6,71	6,01	5,33	4,71	
FKX40/560 N FKX40/560 K	30	Q	46224	42257	38547	31853	26062	21090	16858	13281
		P	4,26	4,49	4,65	4,83	4,81	4,65	4,37	4,00
	40	Q	41343	37725	34347	28268	23025	18535	14718	11490
		P	6,12	6,18	6,19	6,08	5,82	5,45	5,00	4,50
	50	Q	36316	33053	30013	24561	19877	15880	12489	9621
		P	7,77	7,67	7,54	7,17	6,69	6,14	5,54	4,94
60	Q	31181	28278	25582	20767	16654	13162	10208	7711	
	P	9,18	8,95	8,69	8,09	7,42	6,71	5,99	5,31	
70	Q	25973	23437	21090	16924	13393	10416	7912	5797	
	P	10,35	10,00	9,62	8,82	7,99	7,15	6,34	5,60	
FKX40/655 N FKX40/655 K	30	Q	54249	49594	45239	37383	30586	24752	19784	15587
		P	5,01	5,27	5,46	5,66	5,65	5,46	5,13	4,70
	40	Q	48521	44275	40310	33176	27022	21753	17273	13485
		P	7,19	7,26	7,27	7,14	6,83	6,39	5,86	5,28
	50	Q	42621	38792	35224	28825	23328	18637	14657	11291
		P	9,11	9,01	8,85	8,42	7,86	7,21	6,50	5,79
60	Q	36594	33188	30023	24372	19545	15447	11980	9050	
	P	10,77	10,50	10,20	9,49	8,71	7,87	7,04	6,23	
70	Q	30483	27506	24751	19862	15718	12225	9285	6804	
	P	12,14	11,73	11,29	10,35	9,37	8,39	7,44	6,58	
FKX50/660 N FKX50/660 K	30	Q	55186	50450	46020	38029	31114	25179	20126	15856
		P	5,09	5,36	5,56	5,76	5,75	5,55	5,22	4,78
	40	Q	49359	45039	41006	33749	27489	22129	17571	13718
		P	7,31	7,38	7,39	7,26	6,95	6,51	5,96	5,37
	50	Q	43357	39462	35832	29322	23731	18959	14910	11486
		P	9,27	9,16	9,00	8,56	7,99	7,33	6,62	5,89
60	Q	37226	33761	30542	24793	19883	15714	12187	9206	
	P	10,96	10,68	10,37	9,66	8,86	8,01	7,16	6,34	
70	Q	31009	27981	25179	20205	15990	12436	9446	6921	
	P	12,35	11,93	11,48	10,53	9,53	8,54	7,57	6,69	
FKX50/775 N FKX50/775 K	30	Q	64767	59209	54010	44631	36516	29551	23620	18609
		P	5,98	6,29	6,52	6,76	6,74	6,51	6,12	5,61
	40	Q	57928	52859	48125	39608	32261	25971	20622	16099
		P	8,58	8,66	8,68	8,52	8,16	7,63	7,00	6,30
	50	Q	50885	46313	42053	34413	27851	22251	17499	13480
		P	10,88	10,75	10,57	10,05	9,38	8,60	7,76	6,92
60	Q	43689	39622	35844	29097	23335	18442	14303	10804	
	P	12,86	12,54	12,17	11,34	10,40	9,40	8,40	7,44	
70	Q	36393	32838	29550	23712	18766	14595	11085	8123	
	P	14,50	14,00	13,48	12,36	11,19	10,02	8,89	7,85	
FKX50/830 N FKX50/830 K	30	Q	69133	63194	57636	47606	38926	31477	25144	19808
		P	6,40	6,74	7,00	7,26	7,24	6,99	6,57	6,02
	40	Q	61668	56269	51225	42145	34309	27601	21904	17099
		P	9,20	9,29	9,31	9,15	8,76	8,19	7,51	6,76
	50	Q	53991	49141	44620	36507	29533	23583	18538	14282
		P	11,66	11,53	11,34	10,79	10,07	9,23	8,33	7,41
60	Q	46161	41869	37879	30749	24654	19479	15104	11413	
	P	13,78	13,44	13,06	12,16	11,16	10,08	9,01	7,97	
70	Q	38235	34508	31058	24929	19730	15346	11658	8550	
	P	15,53	15,01	14,45	13,26	12,01	10,75	9,53	8,42	
FKX50/980 N FKX50/980 K	30	Q	81175	74192	67663	55889	45709	36976	29545	23272
		P	7,54	7,93	8,21	8,51	8,49	8,20	7,71	7,07
	40	Q	72420	66072	60145	49486	40297	32433	25748	20098
		P	10,80	10,90	10,91	10,71	10,26	9,61	8,82	7,94
	50	Q	63408	57703	52390	42865	34688	27713	21794	16787
		P	13,68	13,52	13,28	12,64	11,80	10,83	9,78	8,71
60	Q	54208	49158	44468	36098	28953	22887	17754	13411	
	P	16,17	15,76	15,30	14,25	13,08	11,83	10,58	9,37	
70	Q	44893	40507	36451	29256	23162	18025	13699	10040	
	P	18,24	17,62	16,95	15,55	14,08	12,61	11,19	9,89	

- 1
- 2
- 3
- 4
- 5
- 6
- 7
- 8

Relating to 25°C suction gas temperature
(FKX50/830 and FKX50/980 on 20 °C suction gas temperature)
without liquid subcooling

 Reduced suction gas temperature

R407C Operating limits

FKX20 / FKX30 / FKX40 / FKX50

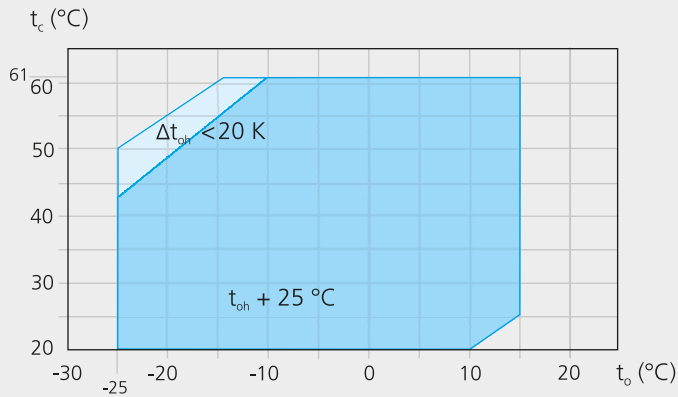

Max. permissible operating pressure (LP/HP)¹⁾: 19/28 bar

¹⁾ LP = low pressure HP = high pressure

- Unlimited application range
- Reduced suction gas temperature

- t_o Evaporating temperature (°C)
- t_c Condensing temperature (°C)
- Δt_{oh} Suction gas superheat (K)
- t_{oh} Suction gas temperature (°C)

Permissible rotation speed:

N Design: 500 - 2600 rpm

K Design: 500 - 3500 rpm

R407C Notes

Operating limits

Compressor operation is possible within the limits shown on the application diagrams. Please note the coloured areas. Compressor application limits should not be chosen for design purposes or continuous operation.

Restrictions to the operating limits may occur when using a capacity regulator.

Performance data

The performance data for R407C are based on 25°C suction gas temperatures without liquid subcooling (FKX50/830 and FKX50/980 on 20 °C suction gas temperature). Compressor speed 1450 rpm.

The values can be stated to judge the overall performance at other speed with the help of the calculation factors below.

Performance data for other operating points, see GEA Bock software.

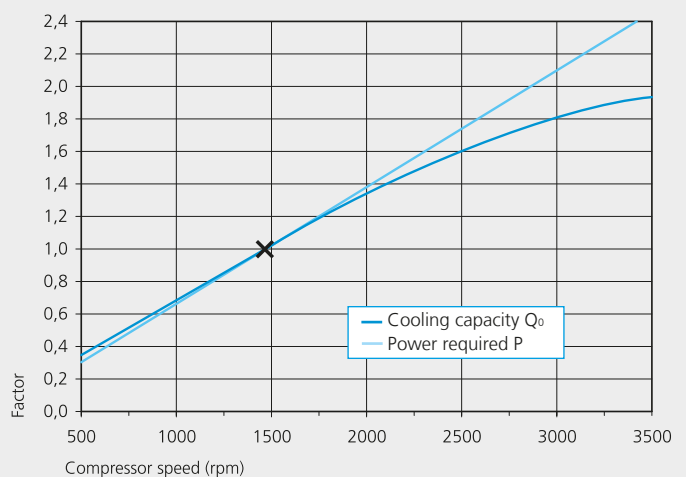

R407C		Performance data								1.450 rpm	
Type	Cond. temp. °C		Cooling capacity \dot{Q}_0 [W]					Power consumption P [kW]			
			Evaporation temperature °C								
			15	12,5	10	5	0	-5	-10	-15	
FKX20/120 N	30	Q	13852	12688	11599	9630	7922	6452	5195	4129	
		P	1,37	1,45	1,51	1,57	1,58	1,53	1,44	1,33	
FKX20/120 K	40	Q	12393	11334	10344	8558	7013	5686	4552	3588	
		P	2,02	2,05	2,05	2,02	1,94	1,82	1,67	1,52	
	50	Q	10876	9925	9037	7442	6067	4889	3884	3030	
		P	2,60	2,57	2,52	2,40	2,25	2,07	1,88	1,69	
FKX20/145 N	30	Q	16679	15278	13966	11596	9540	7769	6256	4972	
		P	1,64	1,74	1,81	1,89	1,90	1,84	1,74	1,60	
FKX20/145 K	40	Q	14923	13648	12455	10305	8445	6846	5481	4320	
		P	2,44	2,46	2,47	2,43	2,33	2,19	2,01	1,83	
	50	Q	13097	11951	10882	8961	7305	5887	4677	3648	
		P	3,13	3,09	3,04	2,89	2,71	2,49	2,26	2,03	
FKX20/170 N	30	Q	19904	18232	16666	13837	11384	9271	7465	5933	
		P	1,96	2,08	2,17	2,26	2,27	2,20	2,07	1,91	
FKX20/170 K	40	Q	17808	16286	14863	12297	10077	8170	6540	5155	
		P	2,91	2,94	2,95	2,90	2,78	2,61	2,40	2,18	
	50	Q	15629	14261	12985	10693	8717	7025	5581	4354	
		P	3,73	3,68	3,62	3,45	3,23	2,97	2,70	2,42	
FKX30/235 N	30	Q	27301	25007	22860	18980	15614	12716	10240	8138	
		P	2,69	2,85	2,97	3,10	3,11	3,01	2,85	2,63	
FKX30/235 K	40	Q	24426	22338	20386	16867	13823	11206	8971	7071	
		P	3,99	4,03	4,05	3,98	3,82	3,58	3,30	2,99	
	50	Q	21437	19561	17812	14667	11957	9636	7656	5971	
		P	5,12	5,06	4,97	4,74	4,43	4,07	3,70	3,32	
FKX30/275 N	30	Q	32410	29687	27138	22532	18536	15096	12156	9661	
		P	3,20	3,38	3,52	3,68	3,69	3,58	3,38	3,12	
FKX30/275 K	40	Q	28998	26519	24202	20024	16409	13303	10650	8394	
		P	4,74	4,79	4,80	4,72	4,53	4,25	3,91	3,55	
	50	Q	25449	23222	21145	17412	14195	11439	9088	7089	
		P	6,07	6,00	5,90	5,62	5,26	4,84	4,39	3,94	
FKX30/325 N	30	Q	38060	34863	31869	26460	21768	17728	14275	11345	
		P	3,75	3,97	4,14	4,32	4,33	4,20	3,97	3,66	
FKX30/325 K	40	Q	34052	31142	28420	23515	19270	15622	12506	9858	
		P	5,56	5,62	5,64	5,55	5,32	4,99	4,60	4,17	
	50	Q	29885	27270	24831	20447	16670	13433	10673	8325	
		P	7,13	7,05	6,93	6,60	6,17	5,68	5,15	4,63	
FKX40/390 N	30	Q	45052	41268	37725	31322	25767	20985	16898	13430	
		P	4,44	4,70	4,90	5,11	5,13	4,97	4,70	4,33	
FKX40/390 K	40	Q	40309	36863	33642	27835	22811	18492	14804	11669	
		P	6,58	6,66	6,67	6,57	6,30	5,91	5,44	4,93	
	50	Q	35376	32280	29393	24204	19732	15901	12634	9854	
		P	8,44	8,35	8,21	7,82	7,31	6,72	6,10	5,48	
FKX40/470 N	30	Q	54466	49891	45607	37866	31151	25369	20429	16236	
		P	5,37	5,69	5,92	6,18	6,20	6,01	5,68	5,24	
FKX40/470 K	40	Q	48732	44566	40672	33651	27577	22356	17897	14107	
		P	7,96	8,05	8,07	7,94	7,61	7,15	6,58	5,96	
	50	Q	42767	39025	35535	29262	23855	19224	15274	11913	
		P	10,21	10,09	9,92	9,45	8,83	8,13	7,38	6,63	
FKX40/560 N	30	Q	64956	59500	54391	45159	37151	30256	24363	19363	
		P	6,41	6,78	7,06	7,37	7,39	7,17	6,77	6,25	
FKX40/560 K	40	Q	58117	53149	48505	40132	32888	26662	21344	16824	
		P	9,49	9,60	9,62	9,47	9,08	8,52	7,85	7,11	
	50	Q	51004	46542	42379	34897	28450	22926	18215	14208	
		P	12,17	12,03	11,83	11,27	10,54	9,69	8,80	7,90	
FKX40/655 N	30	Q	76117	69723	63736	52918	43534	35454	28549	22690	
		P	7,50	7,95	8,28	8,64	8,66	8,40	7,93	7,32	
FKX40/655 K	40	Q	68103	62282	56839	47028	38539	31243	25011	19715	
		P	11,12	11,25	11,28	11,10	10,64	9,99	9,19	8,33	
	50	Q	59768	54538	49660	40893	33338	26865	21345	16649	
		P	14,26	14,10	13,86	13,20	12,35	11,36	10,31	9,26	

Relating to 25 °C suction gas temperature, without liquid subcooling

- 1
- 2
- 3
- 4
- 5
- 6
- 7
- 8

R407C		Performance data								1.450 rpm
Type	Cond. temp. °C		Cooling capacity \dot{Q}_o [W]					Power consumption P [kW]		
			Evaporation temperature °C					-5	-10	-15
			15	12,5	10	5	0			
FKX50/660 N FKX50/660 K	30	Q	77469	70961	64868	53858	44307	36084	29056	23093
		P	7,64	8,09	8,43	8,80	8,81	8,55	8,08	7,45
	40	Q	69312	63388	57849	47863	39223	31798	25456	20065
		P	11,32	11,45	11,48	11,29	10,83	10,16	9,36	8,48
	50	Q	60829	55507	50542	41620	33930	27342	21724	16945
		P	14,52	14,35	14,11	13,44	12,57	11,56	10,49	9,43
FKX50/775 N FKX50/775 K	30	Q	90911	83275	76124	63204	51995	42345	34098	27100
		P	8,97	9,49	9,88	10,31	10,34	10,03	9,47	8,74
	40	Q	81339	74386	67887	56168	46029	37316	29873	23547
		P	13,28	13,43	13,46	13,25	12,71	11,93	10,98	9,95
	50	Q	71384	65139	59312	48842	39818	32087	25494	19885
		P	17,03	16,84	16,56	15,77	14,75	13,57	12,31	11,06
FKX50/830 N FKX50/830 K	30	Q	97448	89219	81521	67628	55599	45259	36437	28960
		P	9,61	10,17	10,59	11,06	11,08	10,76	10,16	9,38
	40	Q	86978	79505	72526	59961	49111	39803	31864	25122
		P	14,24	14,39	14,43	14,20	13,62	12,78	11,77	10,67
	50	Q	76101	69409	63173	51984	42362	34133	27126	21168
		P	18,26	18,05	17,74	16,89	15,79	14,53	13,19	11,85
FKX50/980 N FKX50/980 K	30	Q	114388	104740	95712	79413	65292	53148	42782	33993
		P	11,30	11,96	12,44	12,98	13,00	12,61	11,91	11,00
	40	Q	102124	93359	85170	70423	57681	46744	37413	29488
		P	16,71	16,89	16,94	16,66	15,98	15,00	13,81	12,52
	50	Q	89369	81517	74199	61062	49759	40090	31854	24852
		P	21,41	21,17	20,81	19,83	18,54	17,07	15,49	13,92

Relating to 25°C suction gas temperature
 (FKX50/830 and FKX50/980 on 20 °C suction gas temperature)
 without liquid subcooling

FK Type	Number of cylinders	Swept volume	Displacement (1450 rpm)	Weight	Connections		Oil charge
					Discharge line DV	Suction line SV	
		cm ³	m ³ /h	kg	mm inch	mm inch	Ltr.
FK20/120 N FK20/120 K	2	118	10,3	15	16 5/8	16 5/8	0,7
FK20/145 N FK20/145 K	2	143	12,4	14	16 5/8	16 5/8	0,7
FK20/170 N FK20/170 K	2	170	14,8	14	16 5/8	16 5/8	0,7
FK30/235 N FK30/235 K	2	233	20,3	25	16 5/8	22 7/8	2,0
FK30/275 N FK30/275 K	2	277	24,1	25	22 7/8	28 1 1/8	2,0
FK30/325 N FK30/325 K	2	325	28,3	25	22 7/8	28 1 1/8	2,0
FK40/390 N FK40/390 K	4	385	33,5	34	22 7/8	28 1 1/8	2,0
FK40/470 N FK40/470 K	4	466	40,5	33	28 1 1/8	35 1 3/8	2,0
FK40/560 N FK40/560 K	4	554	48,3	33	28 1 1/8	35 1 3/8	2,0
FK40/655 N FK40/655 K	4	650	46,6	31	35 1 3/8	35 1 3/8	2,0
FK50/660 N FK50/660 K	6	662	57,6	42	35 1 3/8	2 x 35 1 3/8	2,5
FK50/775 N FK50/775 K	6	776	67,6	41	35 1 3/8	2 x 35 1 3/8	2,5
FK50/830 N FK50/830 K	6	831	72,3	43	35 1 3/8	2 x 35 1 3/8	2,5
FK50/980 N FK50/980 K	6	976	84,9	41	35 1 3/8	2 x 35 1 3/8	2,5

For additional technical data see GEA Bock software.

1

2

3

4

5

6

7

8

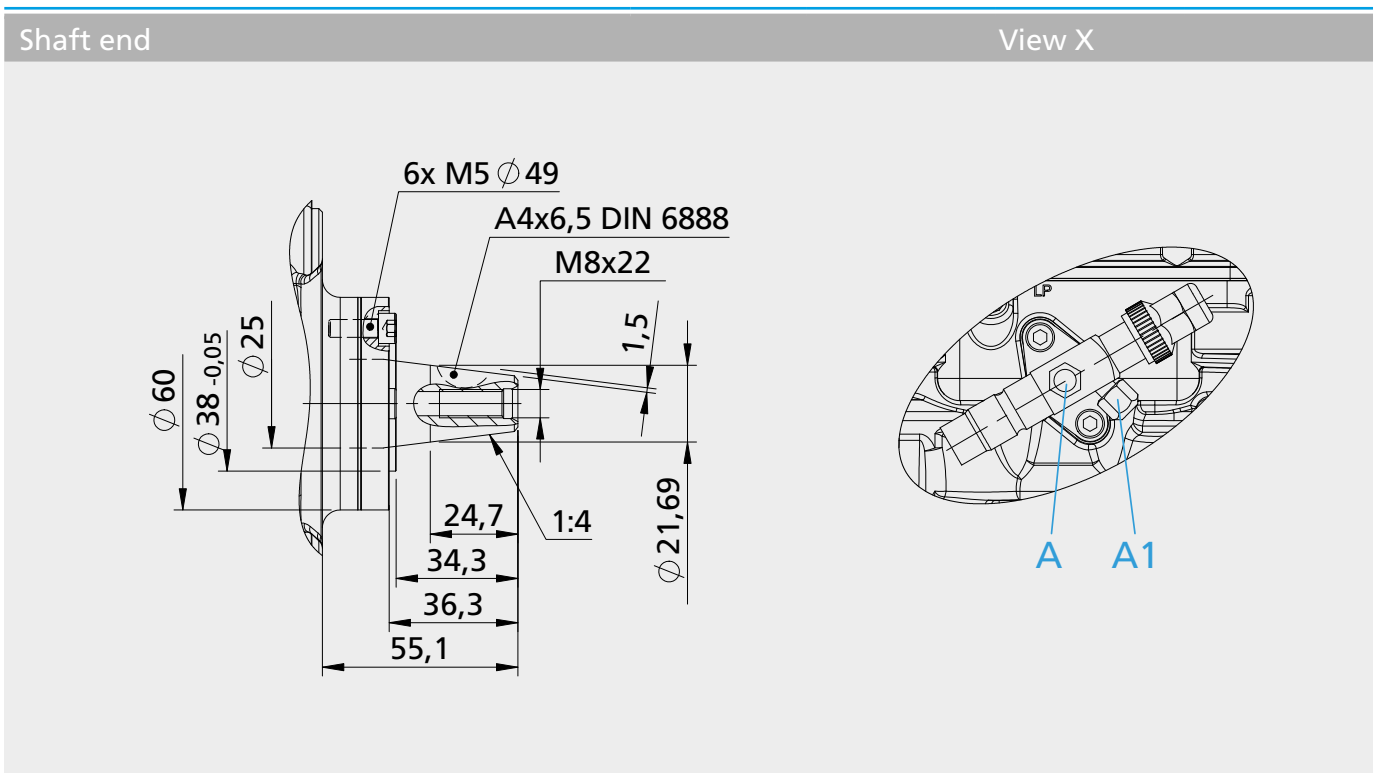
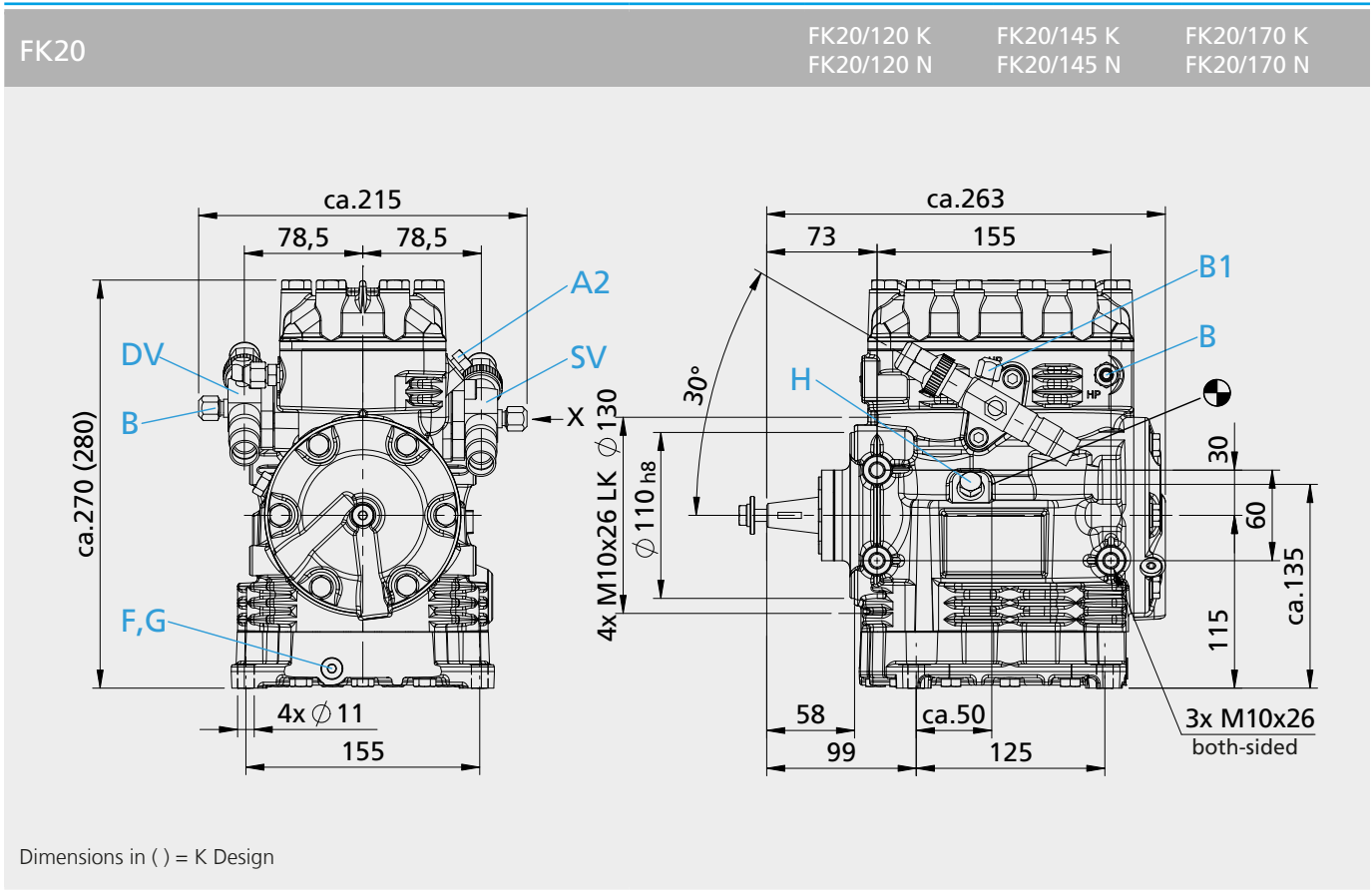

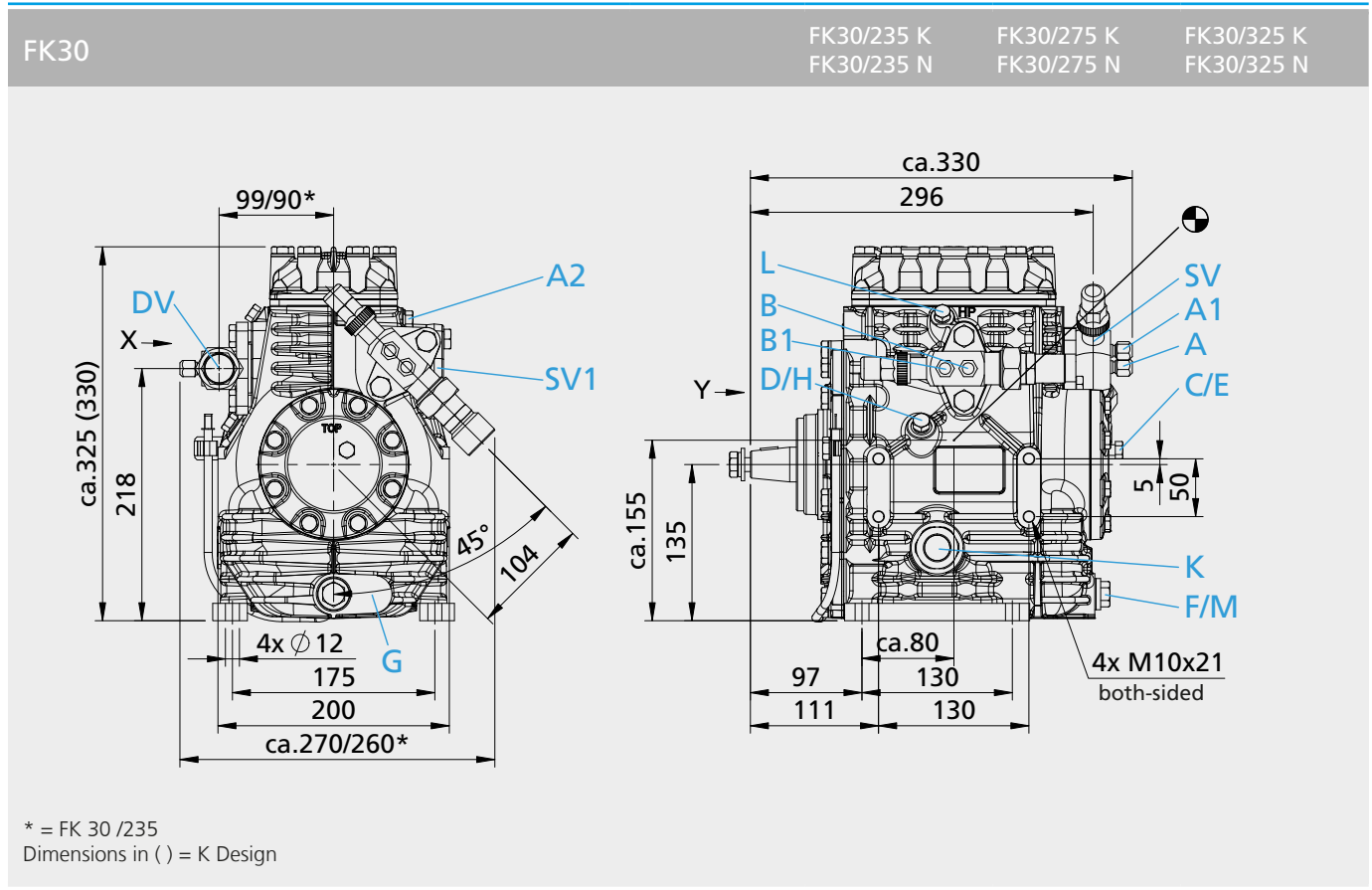

- 1
- 2
- 3
- 4
- 5
- 6
- 7
- 8

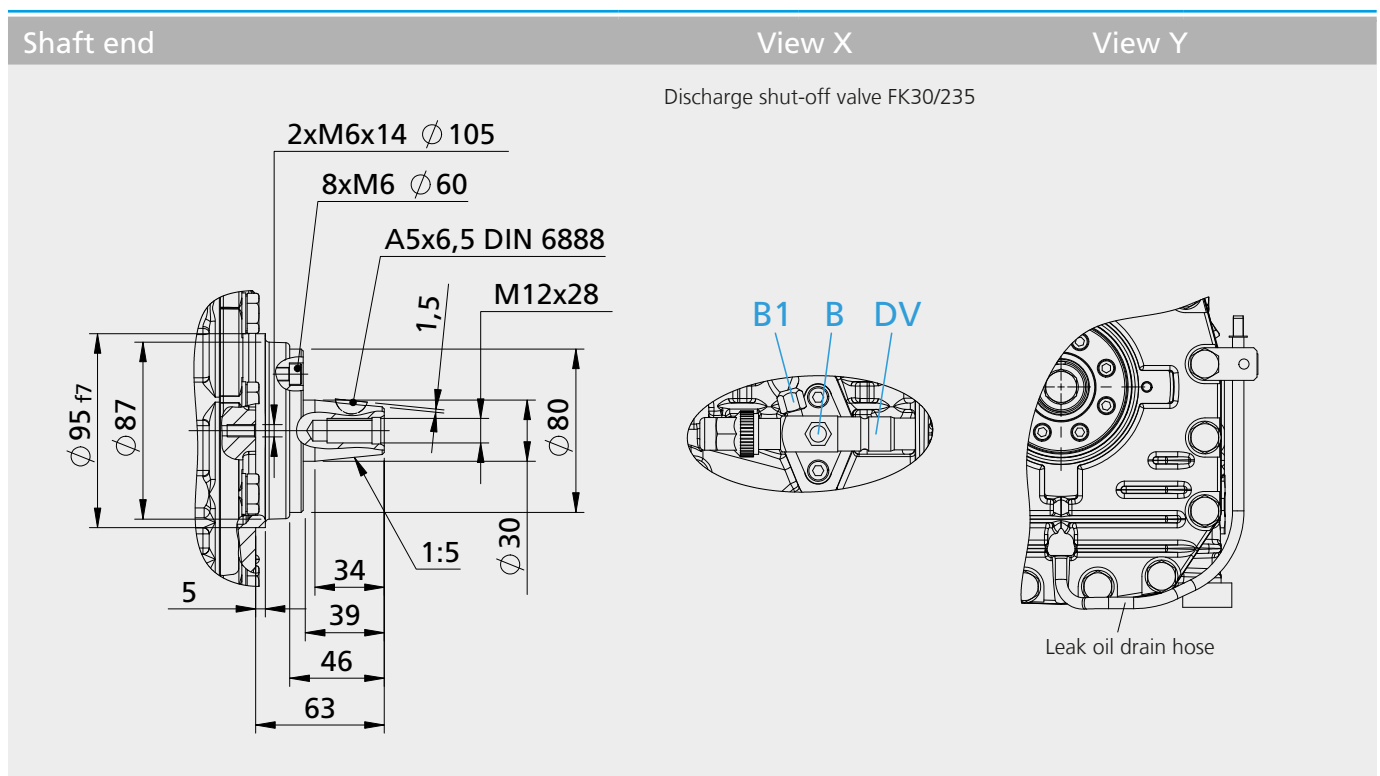

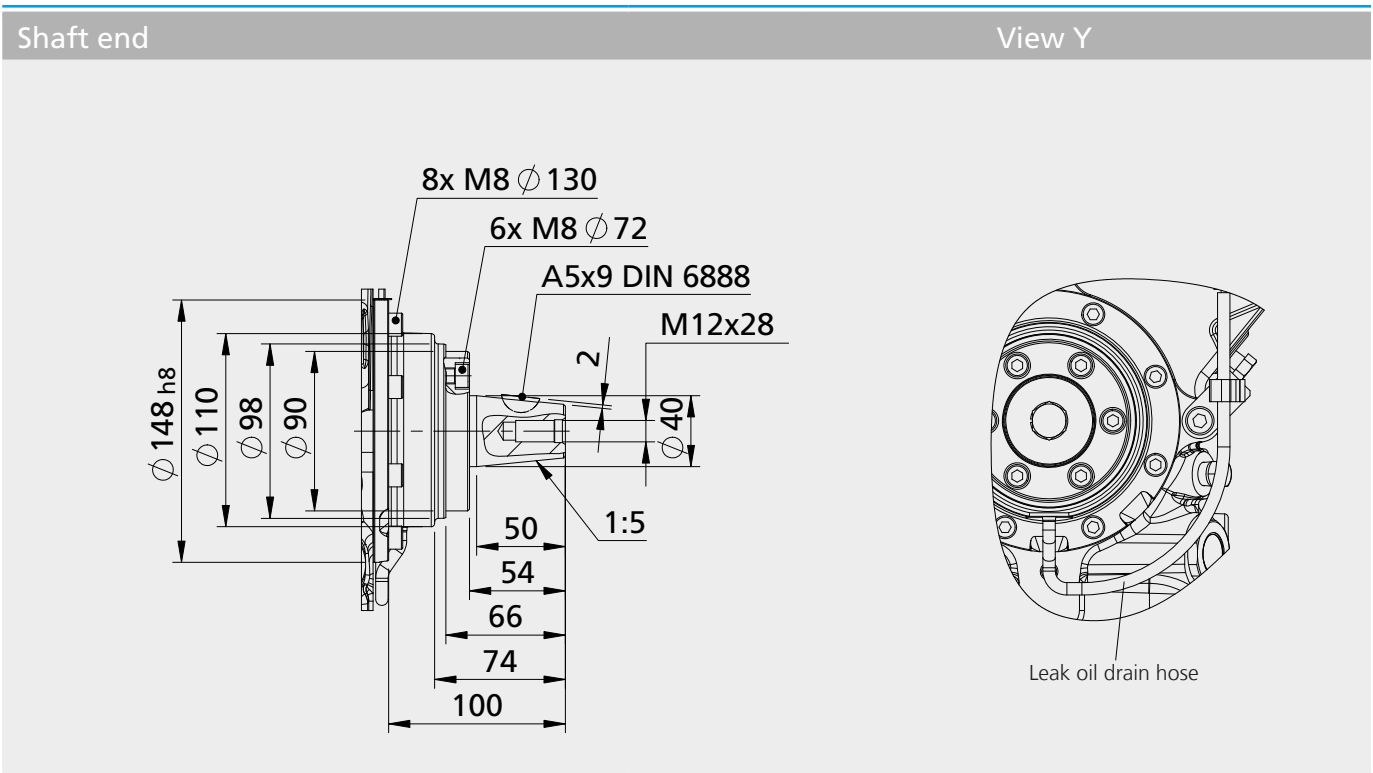
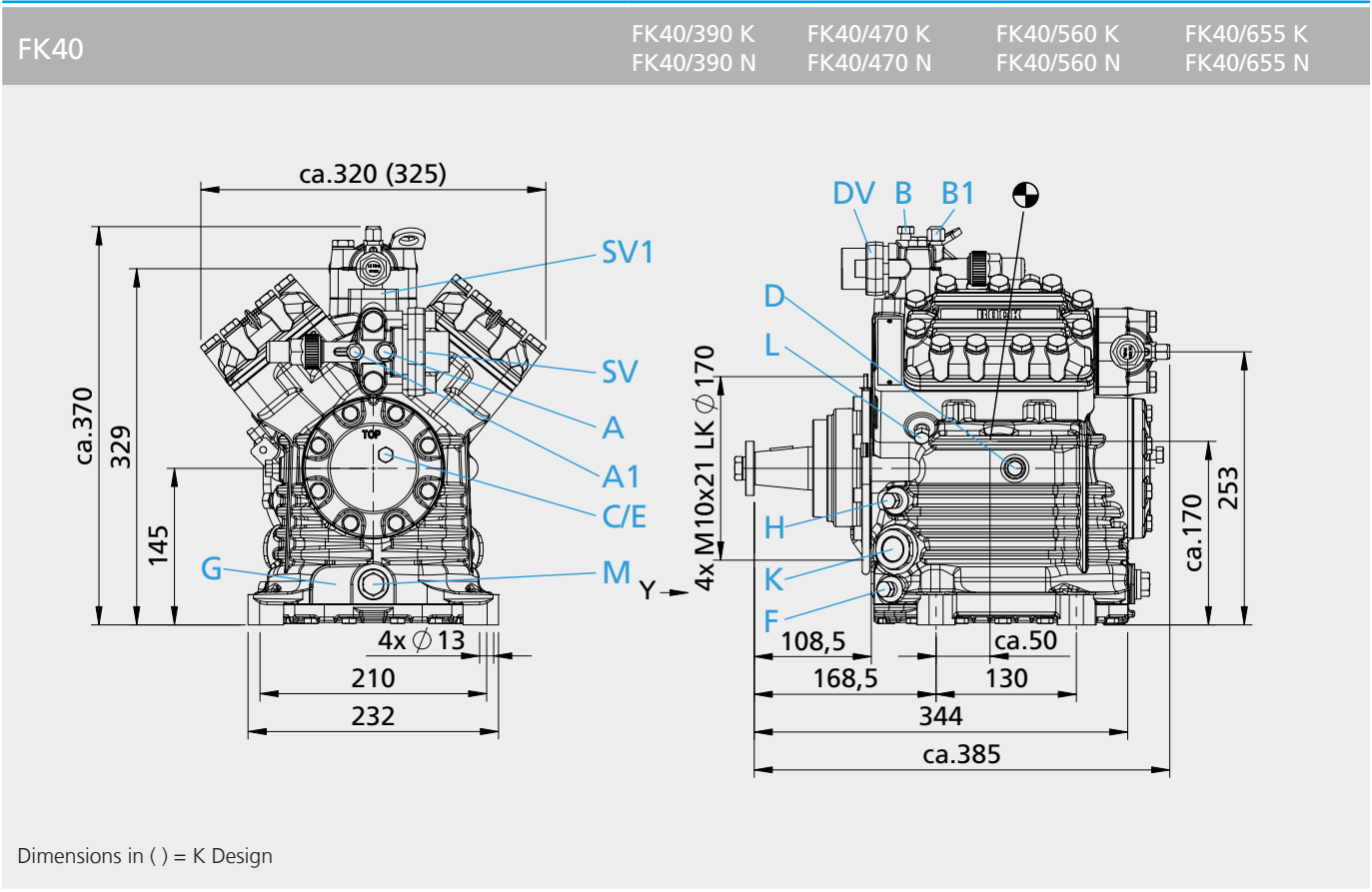

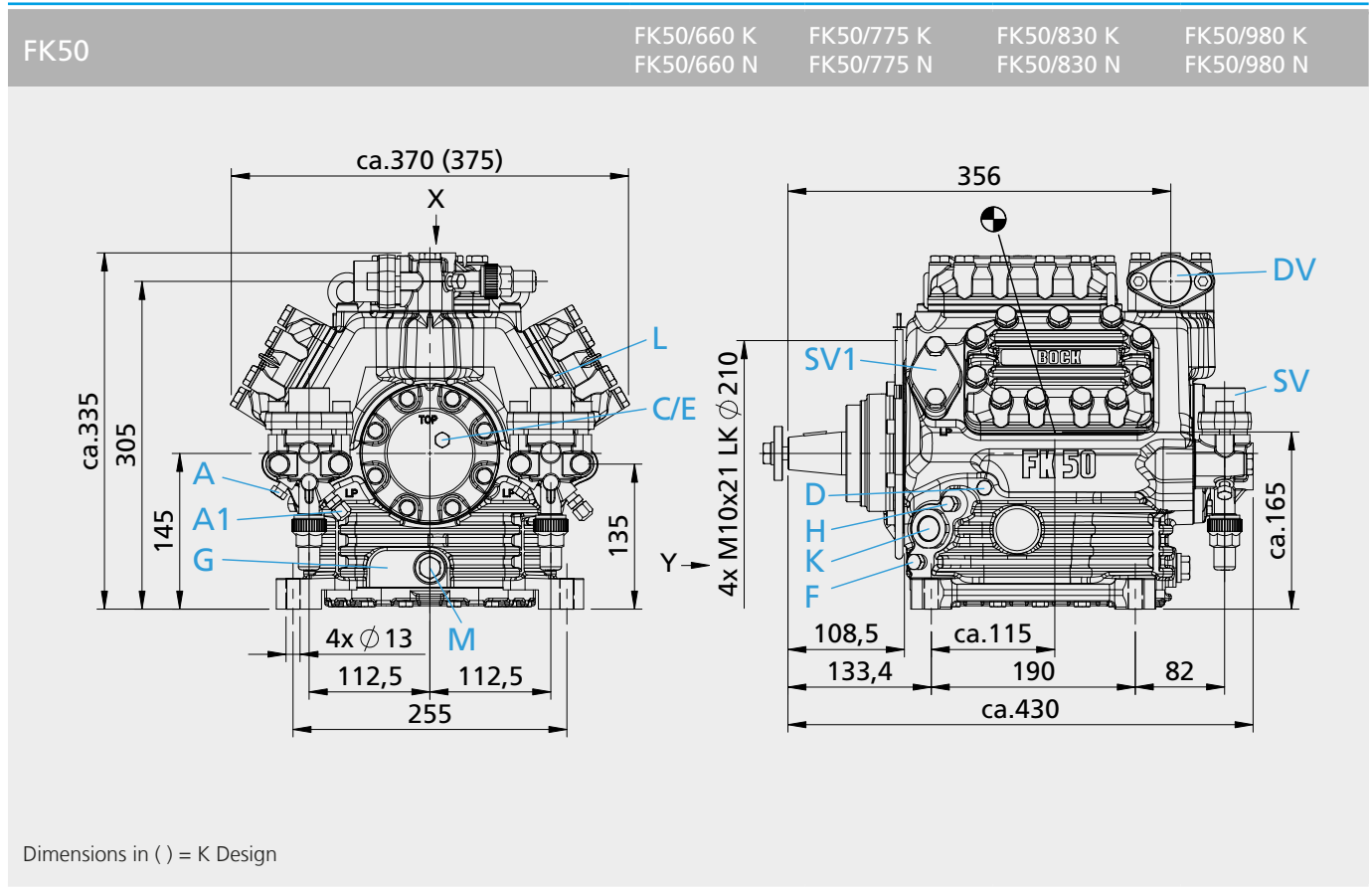

- 1
- 2
- 3
- 4
- 5
- 6
- 7
- 8

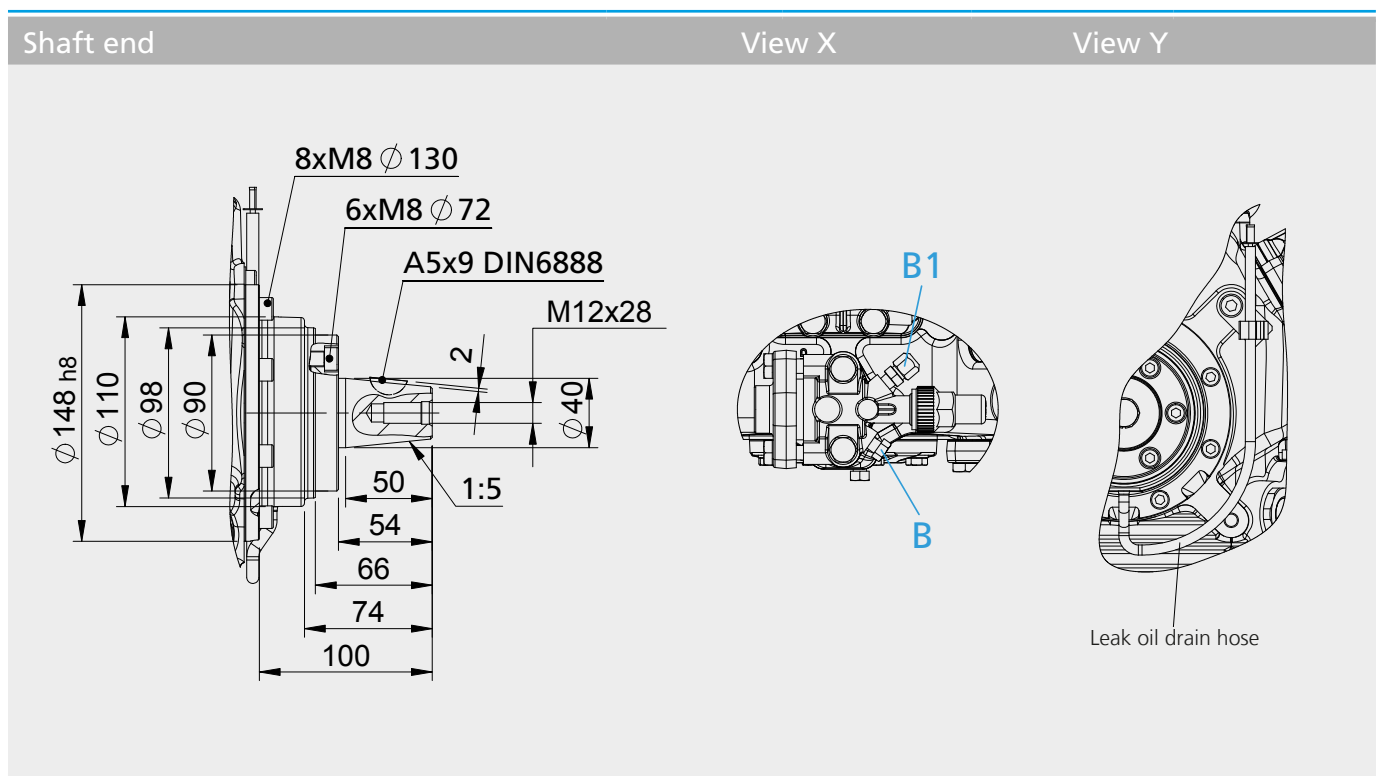

Connections	FK20	FK30	FK40	FK50
SV Suction line DV Discharge line	please refer to technical data page 21			
A Connection suction side, not lockable	7/16 " UNF	7/16 " UNF	1/8 " NPTF	1/8 " NPTF
A1 Connection suction side, lockable	7/16 " UNF	7/16 " UNF	7/16 " UNF	7/16 " UNF
A2 Connection suction side, not lockable	1/8 " NPTF	1/8 " NPTF	-	-
B Connection suction side, not lockable	7/16 " UNF	7/16 " UNF	1/8 " NPTF	1/8 " NPTF
B1 Connection discharge side, lockable	7/16 " UNF	7/16 " UNF	7/16 " UNF	7/16 " UNF
C Connection oil pressure safety switch OIL	-	1/8 " NPTF	1/8 " NPTF	1/8 " NPTF
D Connection oil pressure safety switch LP	-	1/4 " NPTF	1/8 " NPTF	1/8 " NPTF
E Connection oil pressure gauge	-	1/8 " NPTF	1/8 " NPTF	1/8 " NPTF
F Oil drain	G 1/8 "	M 22 x 1,5	1/4 " NPTF	1/4 " NPTF
G Optional connection oil sump heater	○ ¹⁾	○ ¹⁾	○ ¹⁾	○ ¹⁾
H Oil charge plug	1/4 " NPTF	1/4 " NPTF	1/4 " NPTF	1/4 " NPTF
K Sight glass	○ ²⁾	1 1/8 " - 18 UNEF	2 x 1 1/8 " - 18 UNEF	2 x 1 1/8 " - 18 UNEF
L Connection thermal protection thermostat	○ ³⁾	1/8 " NPTF	1/8 " NPTF	1/8 " NPTF
M Oil filter	-	M 22 x 1,5	M 22 x 1,5	M 22 x 1,5
SV1 Optional connection suction line valve	-	●	●	●

● Option available

○ Available on request

¹⁾ No connection available as standard (connection M 22 x 1,5)

²⁾ Standard is without sight glass (connection M 20 x 1)

³⁾ No connection available as standard (1/8" NPTF, intermediate flange required)

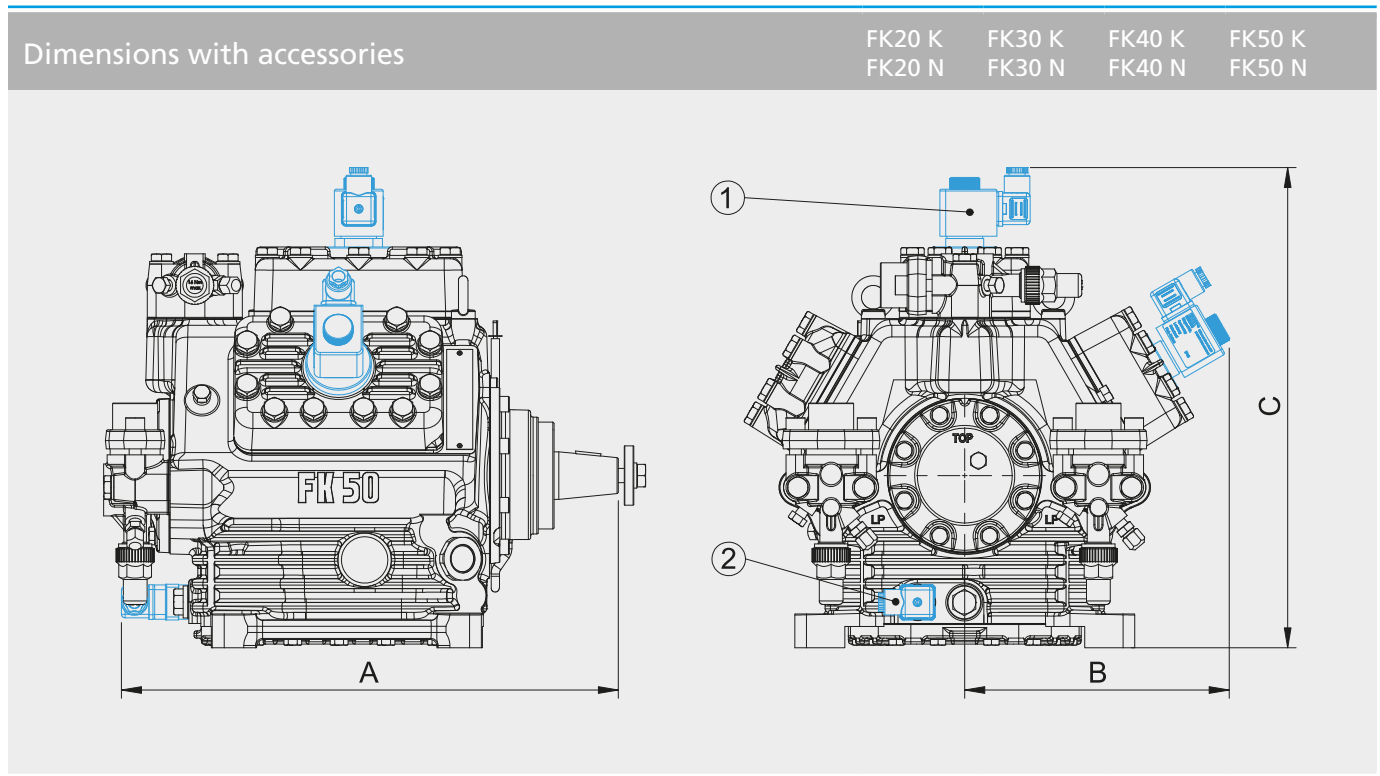

① Capacity regulator ② Oil sump heater

Type	A mm	B mm	C mm
FK20 N, K	ca. 290	-	-
FK30 N, K	ca. 355	-	-
FK40 N	ca. 410	ca. 180	-
FK40 K	ca. 410	ca. 185	-
FK50 N	-	ca. 225	ca. 405
FK50 K	-	ca. 240	ca. 420

- 1
- 2
- 3
- 4
- 5
- 6
- 7
- 8

Scope of supply	FK20	FK30	FK40	FK50
Open type compressor in a light weight aluminium construction, with suction and discharge valves	●	●	●	●
Two cylinder, cylinder arrangement in row	●	●		
Four cylinder, cylinder arrangement in V			●	
Six cylinder, cylinder arrangement in W				●
Integrated oil collecting system for the shaft seal, hose drain design		●	●	●
Seat front bearing flange		●	●	●
Fastening possibility for electromagnetic clutch	●	●	●	●
Possible design variants: ¹⁾				
K-Design	●	●	●	●
N Design	●	●	●	●
Oil charge: FK: FUCHS Reniso SP 46 FKX: FUCHS Reniso Triton SE 55	●	●	●	●
One sight glass		●		
Two sight glasses			●	●
Decompression valve		● ²⁾	●	●
Inert gas charge	●	●	●	●

¹⁾ Only the selected design variant is contained in the scope of supply.

²⁾ Only for models FK30/275 + 325

The scope of supply is the same for the various levels of displacement and the design variants K and N.

In the data concerning the type of compressor, these additions are not taken into account.

Accessories	FK20	FK30	FK40	FK50
① Capacity regulator 24 V DC: 1 capacity regulator = 50 % residual capacity IP65 ¹⁾			●	
Capacity regulator 24 V DC: 1-2 capacity regulator = 66/33 % residual capacity IP65 ¹⁾				●
② Electromagnetic clutch 24 V DC LA 21, Ø 147 mm, 2 x SPA, Power consumption 48 W ^{1) 2) 4)}	●			
Electromagnetic clutch 24 V DC LA 30.01, Ø 174 mm, 2 x SPA, Power consumption 51 W ^{1) 2) 4)}		●		
Electromagnetic clutch 24 V DC LA 16.028, Ø 153 mm, 2 x SPB, Power consumption 60 W ^{1) 2) 4)} bis 775			●	●
Electromagnetic clutch 24 V DC LA 26.02, Ø 203 mm, 2 x SPB, Power consumption 62 W ^{1) 2) 4)} 830 und 980				●
③ Compressor flywheel (three-spoke, grey cast iron) Ø 165 mm, 2 x SPA	●			
Compressor flywheel (three-spoke, grey cast iron) Ø 210 mm, 2 x SPA		●		
Compressor flywheel (three-spoke, grey cast iron) Ø 210 mm, 3 x SPA			●	●
④ Oil sump heater 24 V DC, 40 W IP65 ¹⁾	●			
Oil sump heater 24 V DC, 80 W IP65 ¹⁾		●	●	●
⑤ Thermal protection thermostat (bimetal sensor) IP67	● ³⁾	●	●	●
⑥ Intermediate flange for changing the position of the shut-off valves ²⁾		●	●	●
Oval flange, height 5, 10, 12, 15, 25, 30, 34, 46, 57,5, 62, 71, 75 or 95 mm				
Sight glass	● ⁵⁾			

¹⁾ Other voltages on request

²⁾ Other designs on request

³⁾ With intermediate flange

⁴⁾ Product by Linnig

⁵⁾ Possible just ex works, cannot be retrofitted

The accessories are the same for the various levels of displacement and the design variants N and K. In the data concerning the type of compressor, these additions are not taken into account.

- 1
- 2
- 3
- 4
- 5
- 6
- 7
- 8

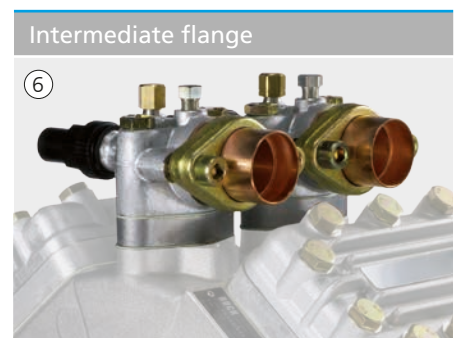
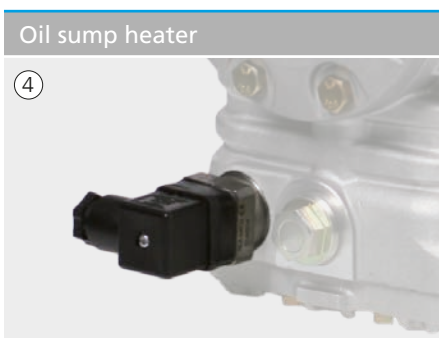
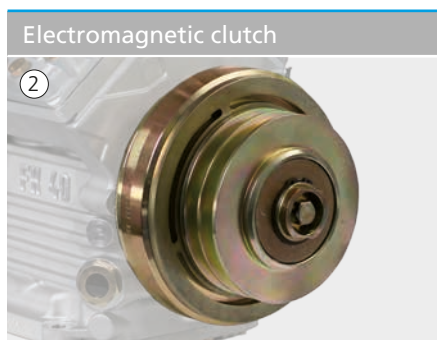



The background of the page is a photograph showing the front-left corner of a white truck on a dark asphalt road. The truck's grille, headlights, and side mirror are visible. In the background, there is a lush green field and a dense line of trees under a bright blue sky with scattered white clouds.

Vehicle Compressors FK for transport refrigeration

At a glance	32
Operating limits and performance data	33
Technical data	36
Dimensions and connections	37
Scope of supply and accessories	43

Bock vehicle compressors of the FK series are the result of decades of experience in transport refrigeration.

The unsurpassed light, compact, robust design and wide speed range are only some of the outstanding features of this unique product range of two, four and six cylinder compressors.

A wide variety of designs can be tailored to suit individual requirements.

The TK version, optimized for low evaporation temperatures, is a special variant for deep freezing.

Type key

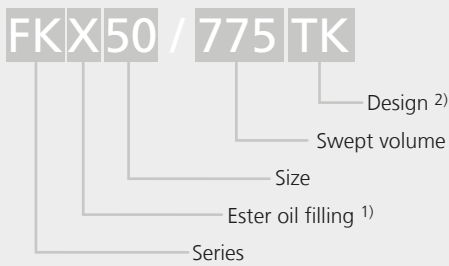

- 1) X - Ester oil filling (HFC refrigerant, e.g. R404A, R507)
- 2) TK - specially for deep freezing

The current program

...4 model sizes with 12 capacity stages from 10,3 to 67,6 m³/h (1450 rpm)

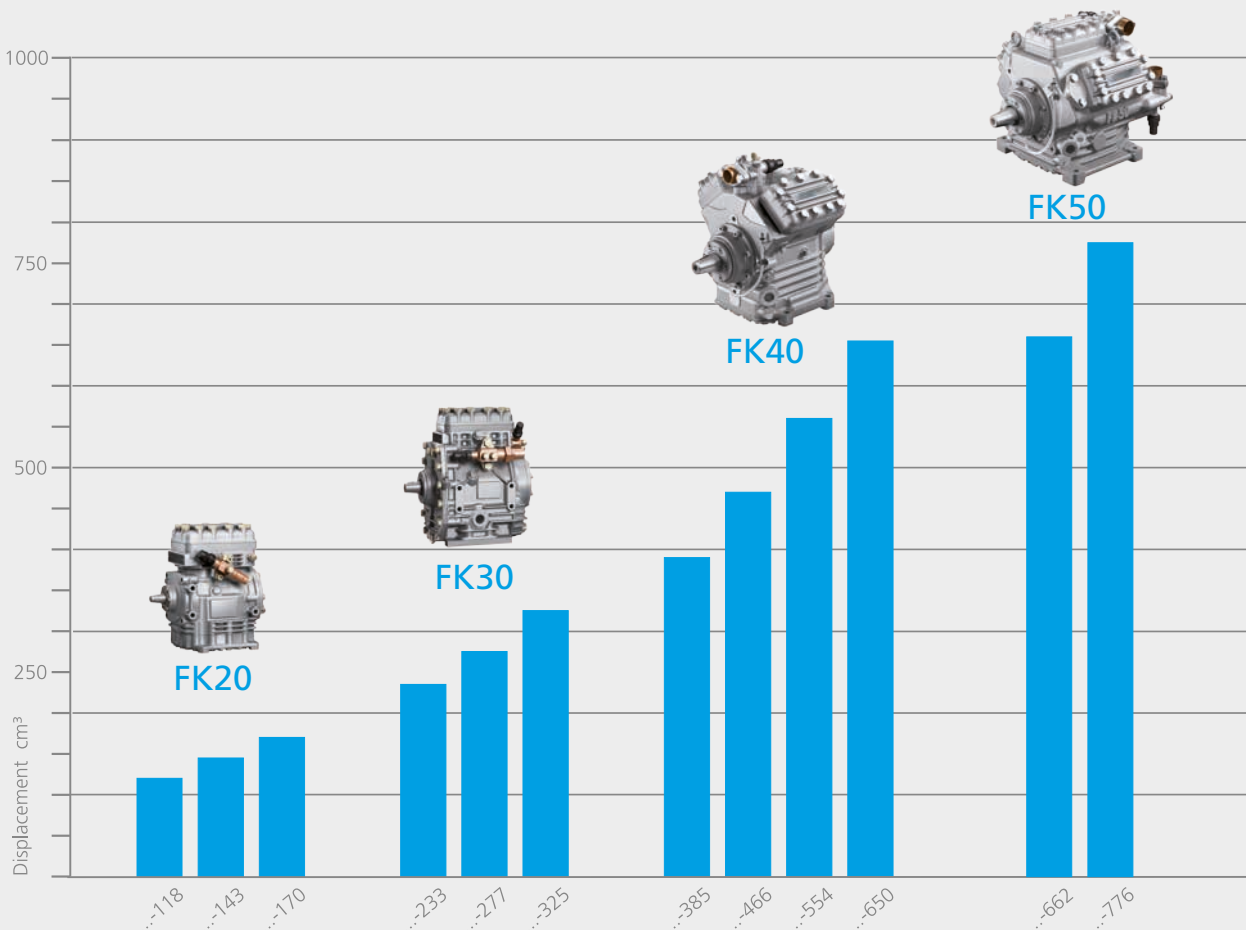

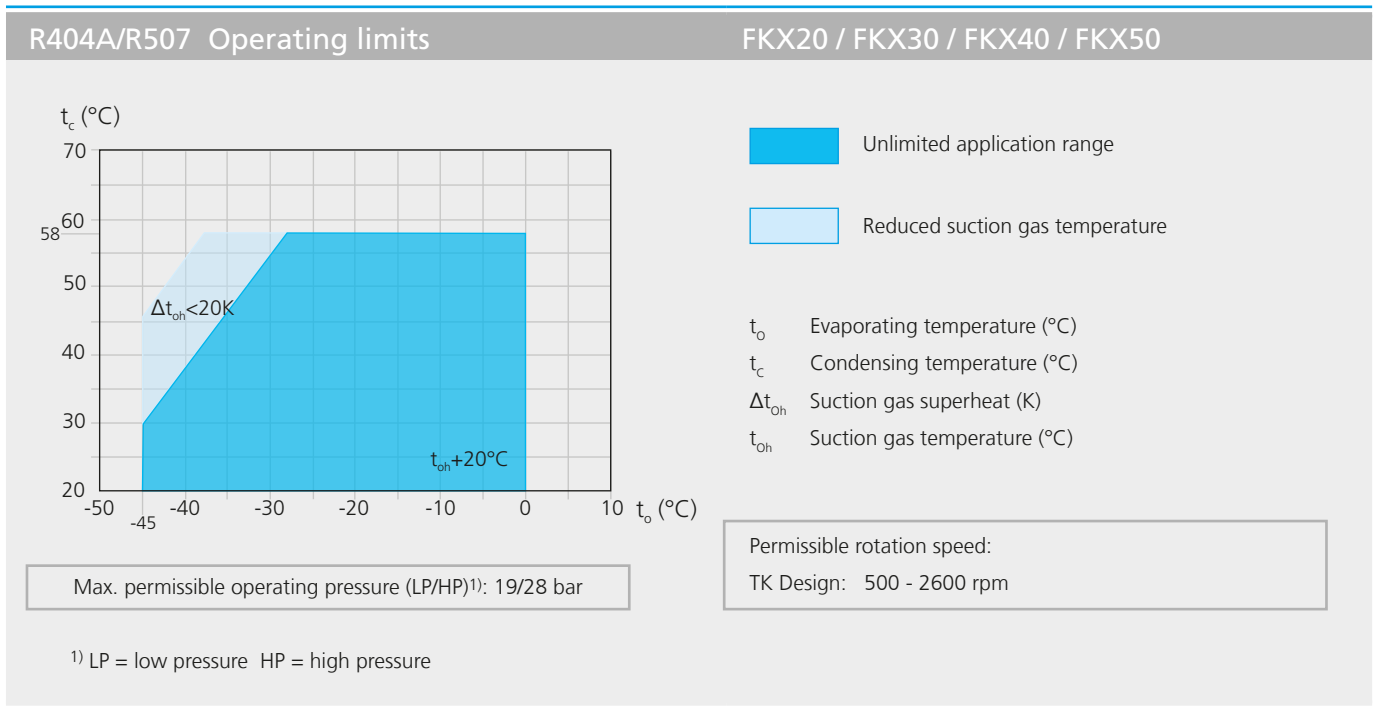

- 1
- 2
- 3
- 4
- 5
- 6
- 7
- 8

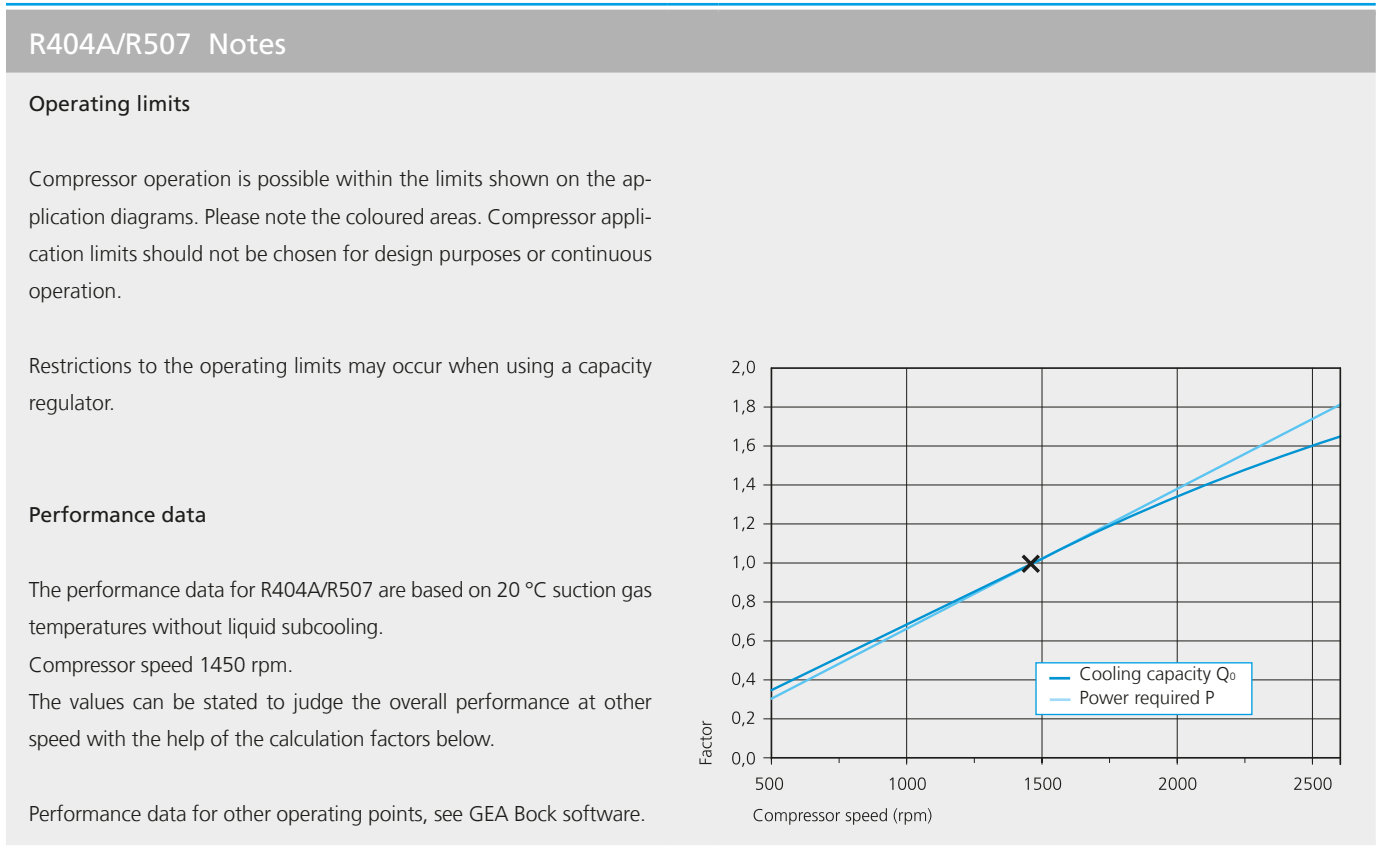

R404A/R507		Performance data								1.450 rpm
Type	Cond. temp. °C		Cooling capacity \dot{Q}_o [W]						Power consumption P [kW]	
			Evaporation temperature °C						-30	-35
			0	-5	-10	-15	-20	-25		
FKX20/120 TK	30	Q	9438	7867	6479	5263	4208	3302	2535	1896
		P	2,09	2,01	1,90	1,77	1,62	1,45	1,28	1,10
	40	Q	8045	6668	5456	4400	3488	2709	2053	1508
		P	2,39	2,25	2,09	1,92	1,72	1,52	1,31	1,10
	50	Q	6620	5443	4414	3524	2762	2117	1579	1135
		P	2,65	2,46	2,25	2,03	1,80	1,56	1,32	1,08
FKX20/145 TK	30	Q	11362	9471	7800	6336	5065	3975	3052	2283
		P	2,52	2,42	2,29	2,13	1,95	1,75	1,54	1,33
	40	Q	9686	8027	6569	5297	4199	3261	2471	1816
		P	2,88	2,71	2,52	2,31	2,07	1,83	1,58	1,33
	50	Q	7970	6552	5314	4243	3326	2549	1900	1366
		P	3,20	2,96	2,71	2,44	2,16	1,88	1,59	1,30
FKX20/170 TK	30	Q	13561	11304	9310	7563	6046	4744	3643	2725
		P	3,01	2,89	2,73	2,54	2,32	2,09	1,84	1,58
	40	Q	11560	9581	7840	6322	5011	3892	2949	2167
		P	3,44	3,24	3,01	2,75	2,48	2,19	1,89	1,59
	50	Q	9513	7820	6343	5064	3969	3043	2268	1631
		P	3,81	3,54	3,24	2,92	2,58	2,24	1,89	1,55
FKX30/235 TK	30	Q	20377	17011	14041	11442	9187	7251	5608	4231
		P	3,94	3,83	3,66	3,44	3,17	2,88	2,56	2,23
	40	Q	17437	14495	11911	9657	7710	6042	4628	3442
		P	4,66	4,41	4,11	3,77	3,40	3,01	2,61	2,21
	50	Q	14498	11985	9791	7889	6254	4860	3680	2690
		P	5,28	4,89	4,47	4,02	3,56	3,08	2,61	2,15
FKX30/275 TK	30	Q	24191	20195	16670	13584	10907	8609	6658	5024
		P	4,67	4,55	4,34	4,08	3,77	3,42	3,04	2,65
	40	Q	20701	17209	14140	11465	9153	7173	5495	4086
		P	5,53	5,24	4,88	4,48	4,04	3,57	3,10	2,63
	50	Q	17212	14229	11624	9366	7425	5769	4369	3193
		P	6,27	5,81	5,31	4,78	4,22	3,66	3,10	2,56
FKX30/325 TK	30	Q	28407	23715	19575	15951	12808	10109	7818	5899
		P	5,49	5,34	5,10	4,79	4,42	4,01	3,57	3,11
	40	Q	24309	20208	16604	13463	10748	8423	6452	4798
		P	6,50	6,15	5,73	5,26	4,74	4,20	3,64	3,09
	50	Q	20212	16709	13649	10998	8719	6775	5130	3750
		P	7,36	6,82	6,24	5,61	4,96	4,30	3,64	3,00

Relating to 20 °C suction gas temperature, without liquid subcooling

 Reduced suction gas temperature

R404A/R507		Performance data								1.450 rpm
Type	Cond. temp. °C		Cooling capacity \dot{Q}_o [W]						Power consumption P [kW]	
			Evaporation temperature °C							
			0	-5	-10	-15	-20	-25	-30	-35
FKX40/390 TK	30	Q	31916	26566	21831	17679	14078	10994	8397	6252
		P	6,69	6,39	6,00	5,53	5,00	4,43	3,85	3,28
	40	Q	27353	22603	18421	14775	11632	8961	6729	4903
		P	7,67	7,17	6,60	5,97	5,30	4,62	3,95	3,30
	50	Q	22482	18375	14790	11693	9054	6839	5016	3553
		P	8,36	7,68	6,95	6,18	5,40	4,62	3,88	3,18
FKX40/470 TK	30	Q	38585	32117	26393	21373	17019	13292	10151	7559
		P	8,09	7,73	7,25	6,68	6,04	5,36	4,66	3,96
	40	Q	33069	27326	22270	17862	14063	10834	8135	5928
		P	9,27	8,67	7,98	7,21	6,41	5,59	4,78	4,00
	50	Q	27179	22214	17880	14137	10946	8268	6064	4295
		P	10,10	9,28	8,40	7,47	6,53	5,59	4,69	3,85
FKX40/560 TK	30	Q	46016	38303	31476	25490	20297	15851	12106	9015
		P	9,65	9,22	8,65	7,97	7,21	6,39	5,55	4,72
	40	Q	39437	32588	26559	21302	16771	12920	9702	7070
		P	11,06	10,34	9,51	8,60	7,65	6,67	5,70	4,76
	50	Q	32414	26493	21323	16859	13054	9860	7232	5123
		P	12,05	11,07	10,01	8,91	7,78	6,67	5,59	4,59
FKX40/655 TK	30	Q	54393	45269	37218	30176	24081	18869	14477	10842
		P	11,04	10,70	10,14	9,41	8,55	7,62	6,66	5,71
	40	Q	46423	38384	31328	25192	19913	15427	11671	8582
		P	12,90	12,14	11,23	10,19	9,09	7,96	6,86	5,84
	50	Q	38345	31422	25393	20194	15762	12033	8945	6433
		P	14,50	13,38	12,15	10,86	9,57	8,30	7,12	6,07
FKX50/660 TK	30	Q	54596	45313	37094	29883	23622	18251	13713	9951
		P	10,36	10,13	9,68	9,04	8,26	7,36	6,40	5,39
	40	Q	46656	38444	31210	24897	19447	14801	10902	7691
		P	12,25	11,62	10,80	9,85	8,78	7,64	6,47	5,31
	50	Q	38303	31232	25052	19707	15137	11286	8094	5504
		P	13,75	12,74	11,60	10,35	9,04	7,70	6,36	5,06
FKX50/775 TK	30	Q	63521	53066	43678	35333	28005	21669	16298	11867
		P	12,43	12,15	11,58	10,78	9,81	8,71	7,54	6,37
	40	Q	54484	45085	36703	29311	22884	17397	12824	9141
		P	14,72	13,90	12,87	11,66	10,35	8,98	7,60	6,29
	50	Q	45112	36867	29588	23247	17820	13282	9606	6767
		P	16,62	15,32	13,86	12,30	10,70	9,11	7,58	6,17

Relating to 20 °C suction gas temperature, without liquid subcooling

 Reduced suction gas temperature

- 1
- 2
- 3
- 4
- 5
- 6
- 7
- 8

FK Type	Number of cylinders	Swept volume	Displacement (1450 rpm)	Weight	Connections		Oil charge
					Discharge line DV	Suction line SV	
					mm inch	mm inch	
		cm ³	m ³ /h	kg			Ltr.
FK20/120 TK	2	118	10,3	15	16 5/8	16 5/8	0,7
FK20/145 TK	2	143	12,4	14	16 5/8	16 5/8	0,7
FK20/170 TK	2	170	14,8	14	16 5/8	16 5/8	0,7
FK30/235 TK	2	233	20,3	25	16 5/8	22 7/8	2,0
FK30/275 TK	2	277	24,1	25	22 7/8	28 1 1/8	2,0
FK30/325 TK	2	325	28,3	25	22 7/8	28 1 1/8	2,0
FK40/390 TK	4	385	33,5	34	22 7/8	28 1 1/8	2,0
FK40/470 TK	4	466	40,5	33	28 1 1/8	35 1 3/8	2,0
FK40/560 TK	4	554	48,3	33	28 1 1/8	35 1 3/8	2,0
FK40/655 TK	4	650	46,6	31	35 1 3/8	35 1 3/8	2,0
FK50/660 TK	6	662	57,6	42	35 1 3/8	2 x 35 1 3/8	2,5
FK50/775 TK	6	776	67,6	41	35 1 3/8	2 x 35 1 3/8	2,5

For additional technical data see GEA Bock software.

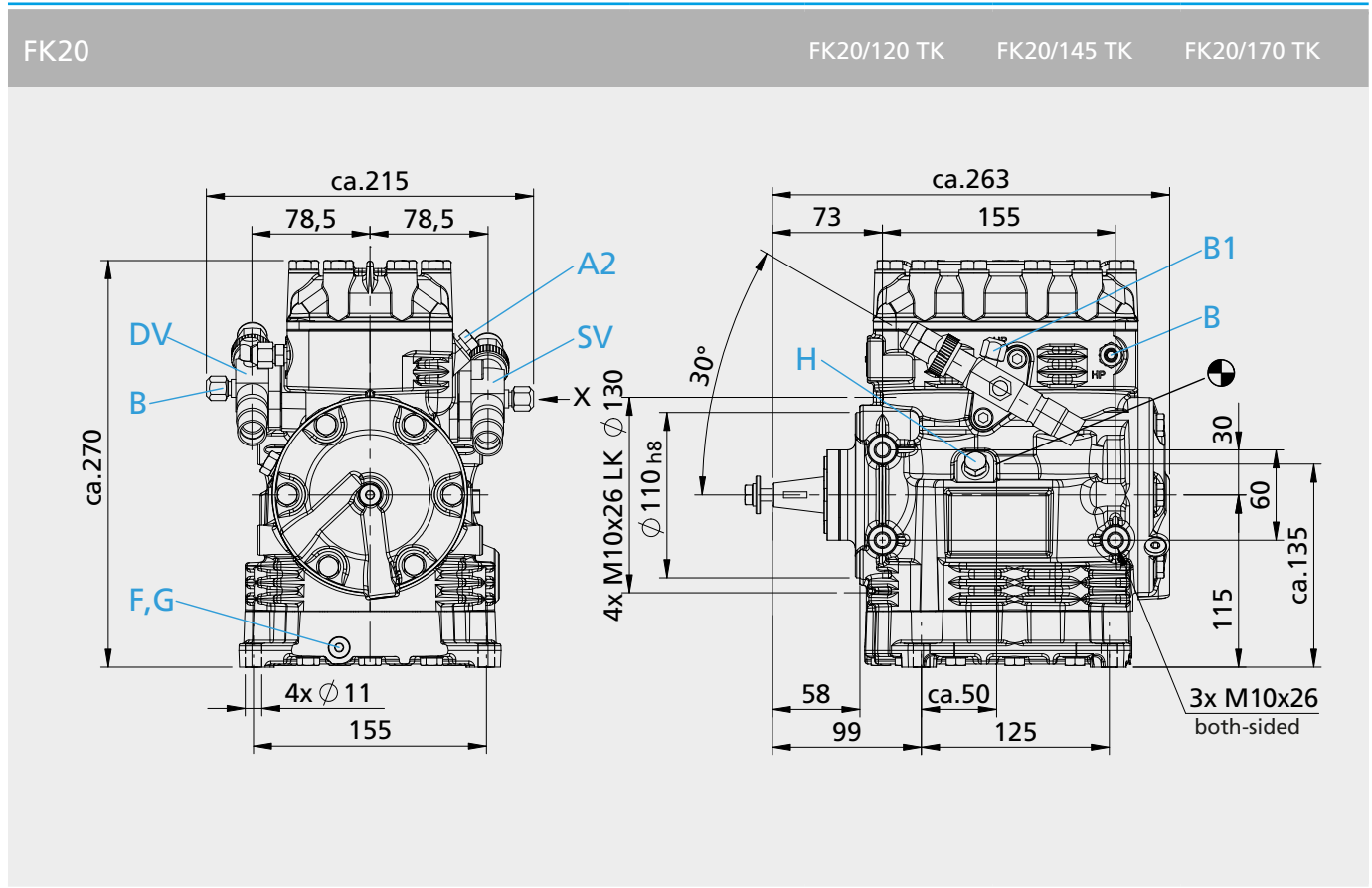

- 1
- 2
- 3
- 4
- 5
- 6
- 7
- 8

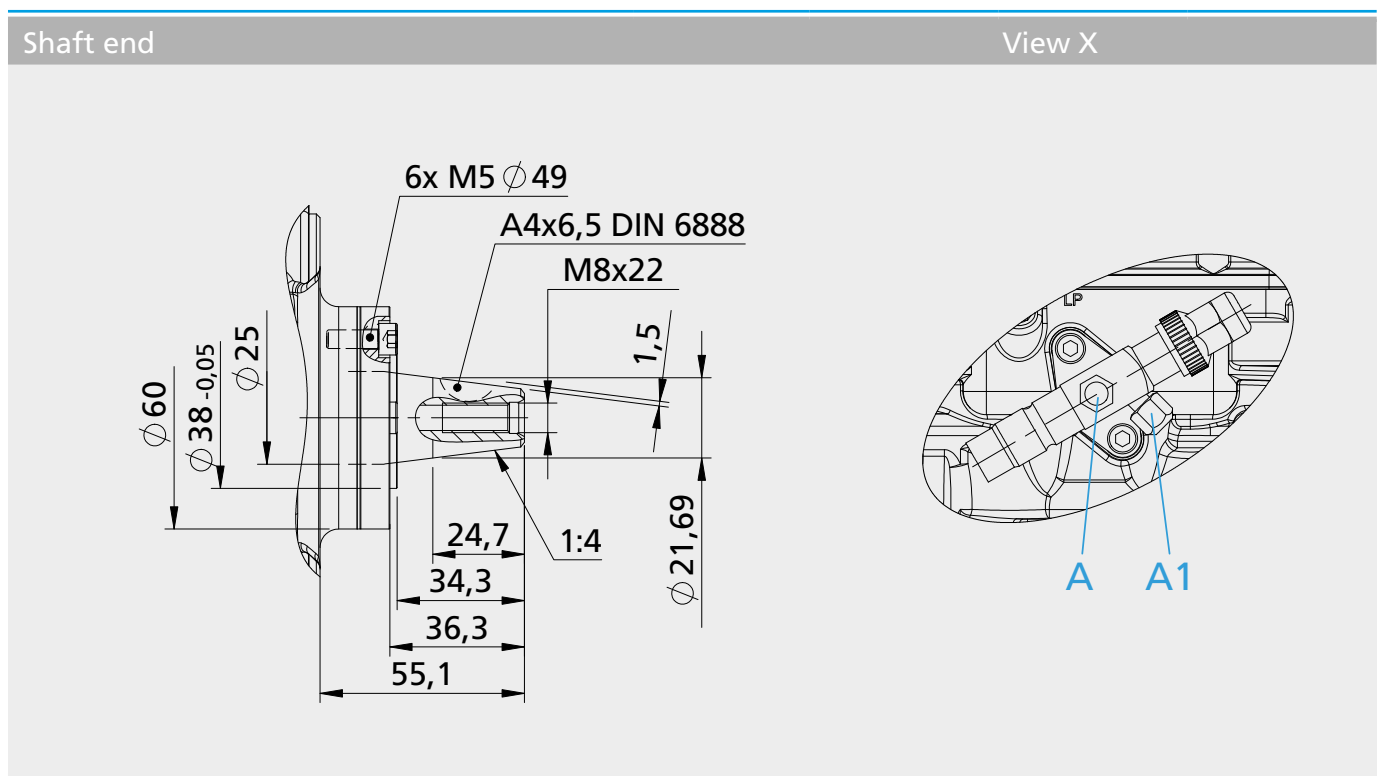

FK30

FK30/235 TK

FK30/275 TK

FK30/325 TK

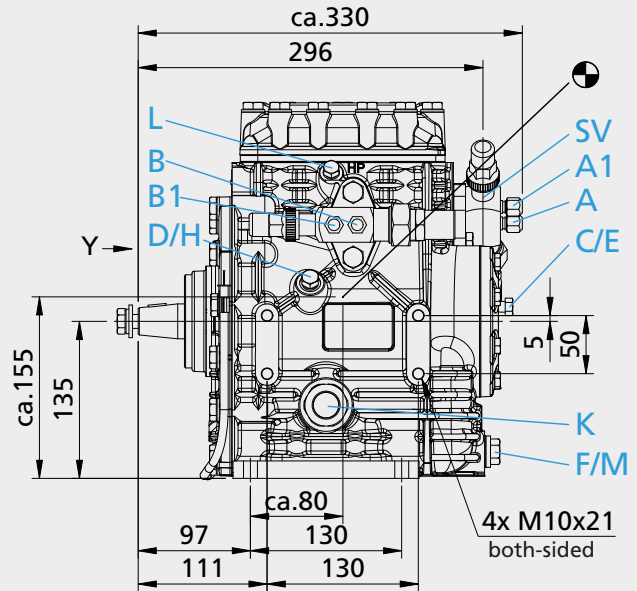
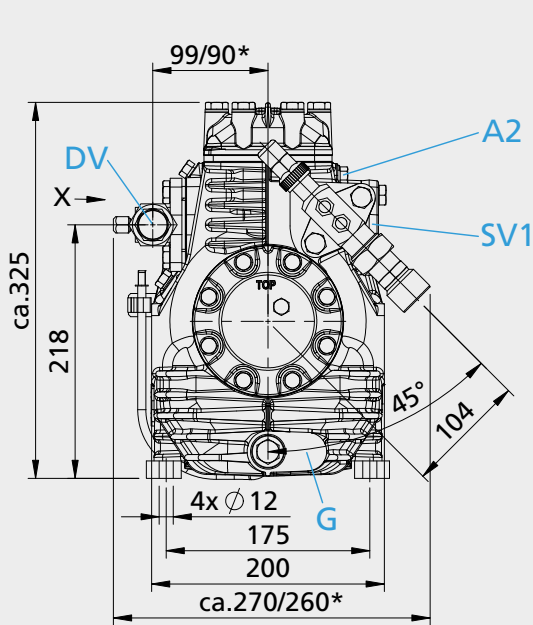

* = FK 30 /235

Shaft end

View X

View Y

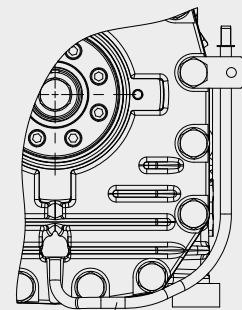
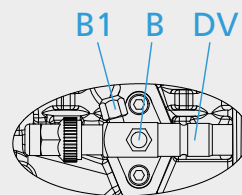
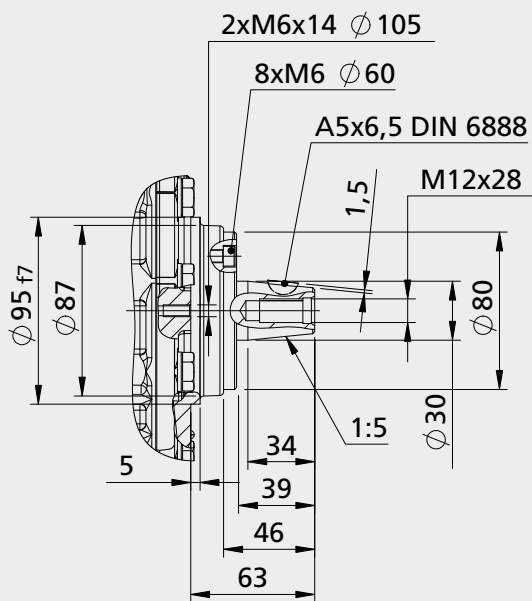

Leak oil drain hose

FK40

FK40/390 TK

FK40/470 TK

FK40/560 TK

FK40/655 TK

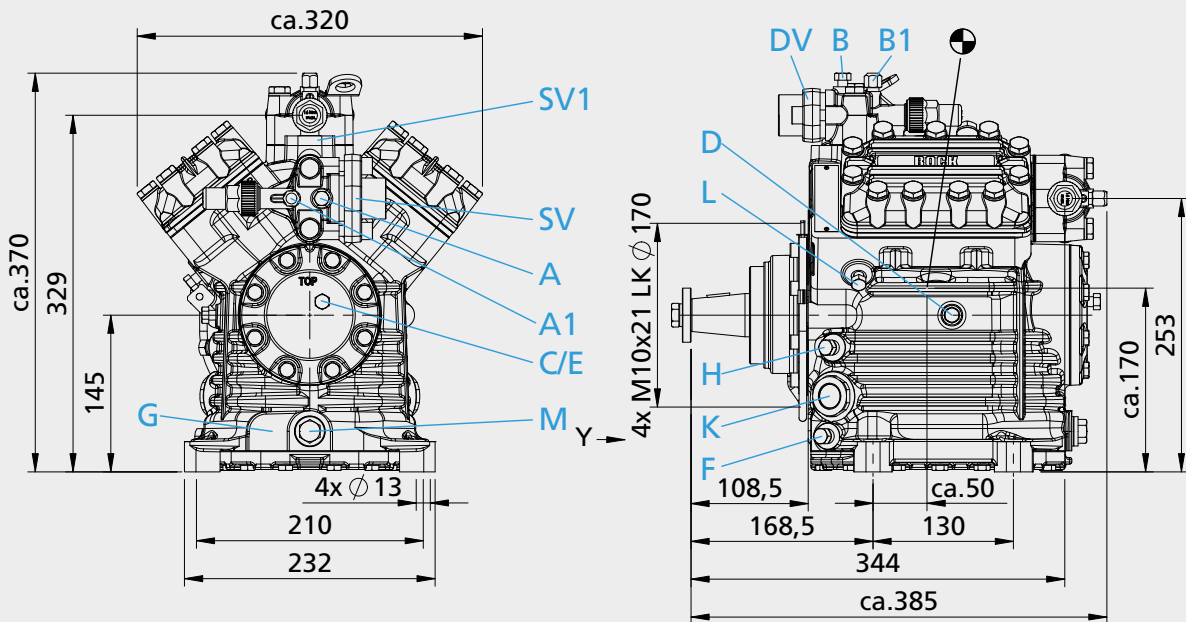

- 1
- 2
- 3
- 4
- 5
- 6
- 7
- 8

Shaft end

View Y

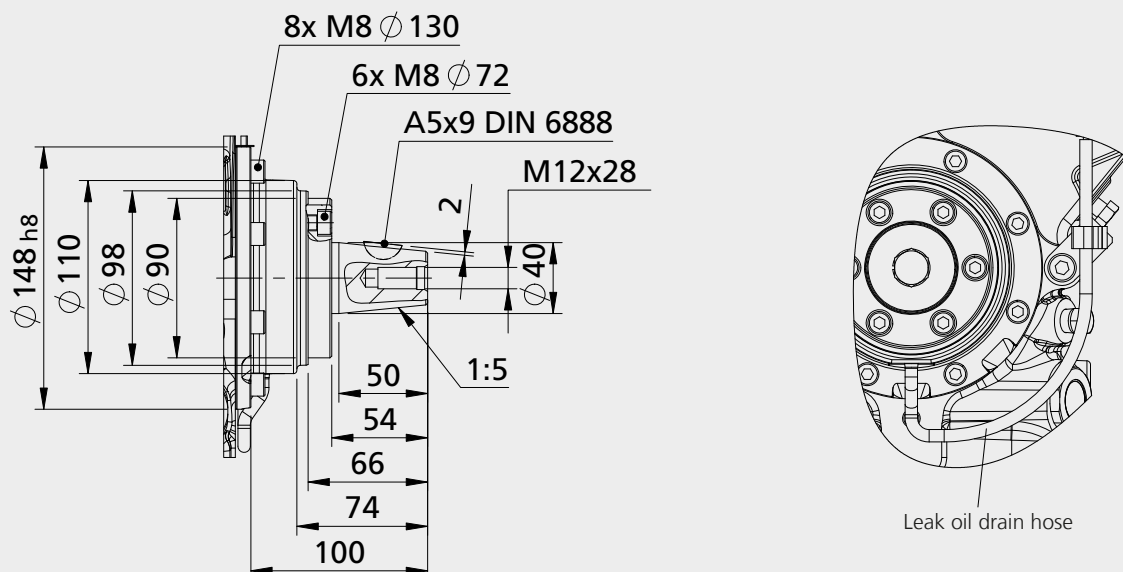

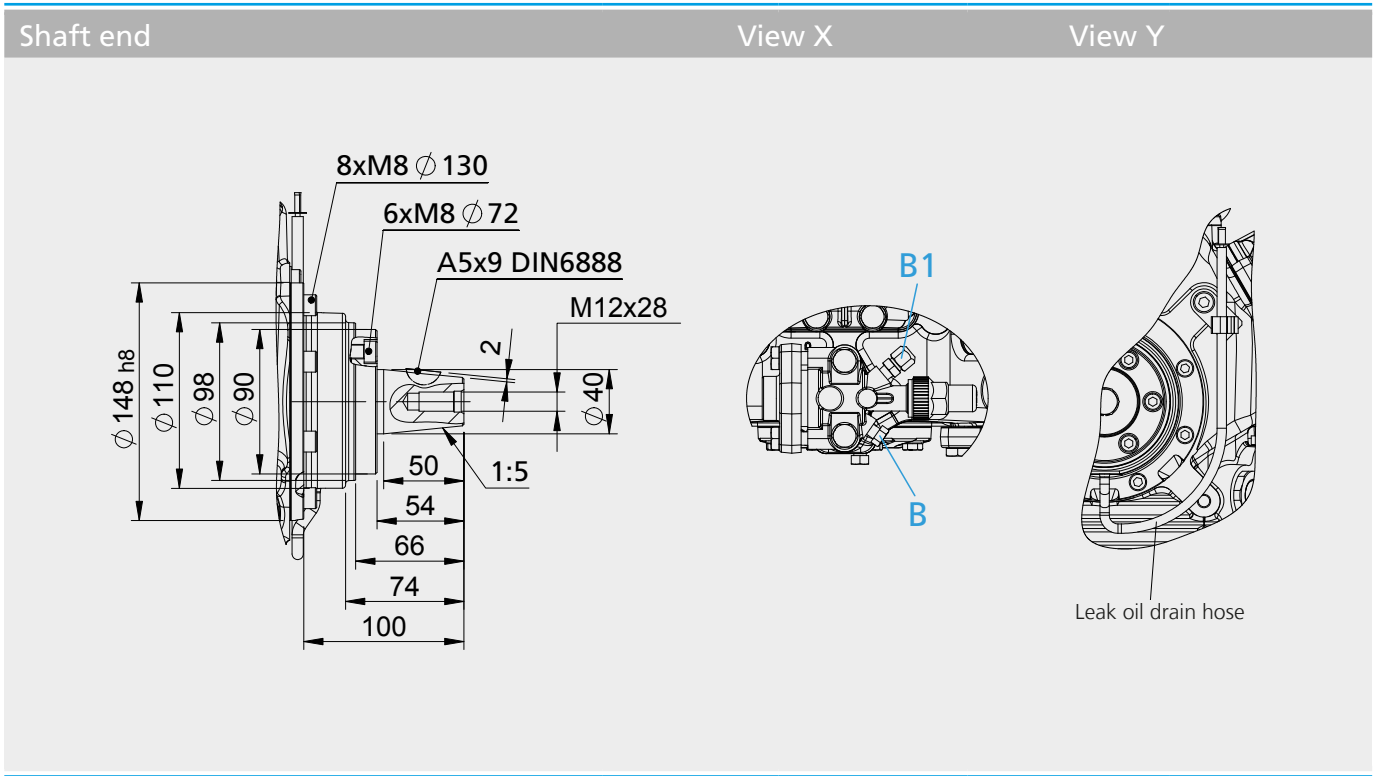
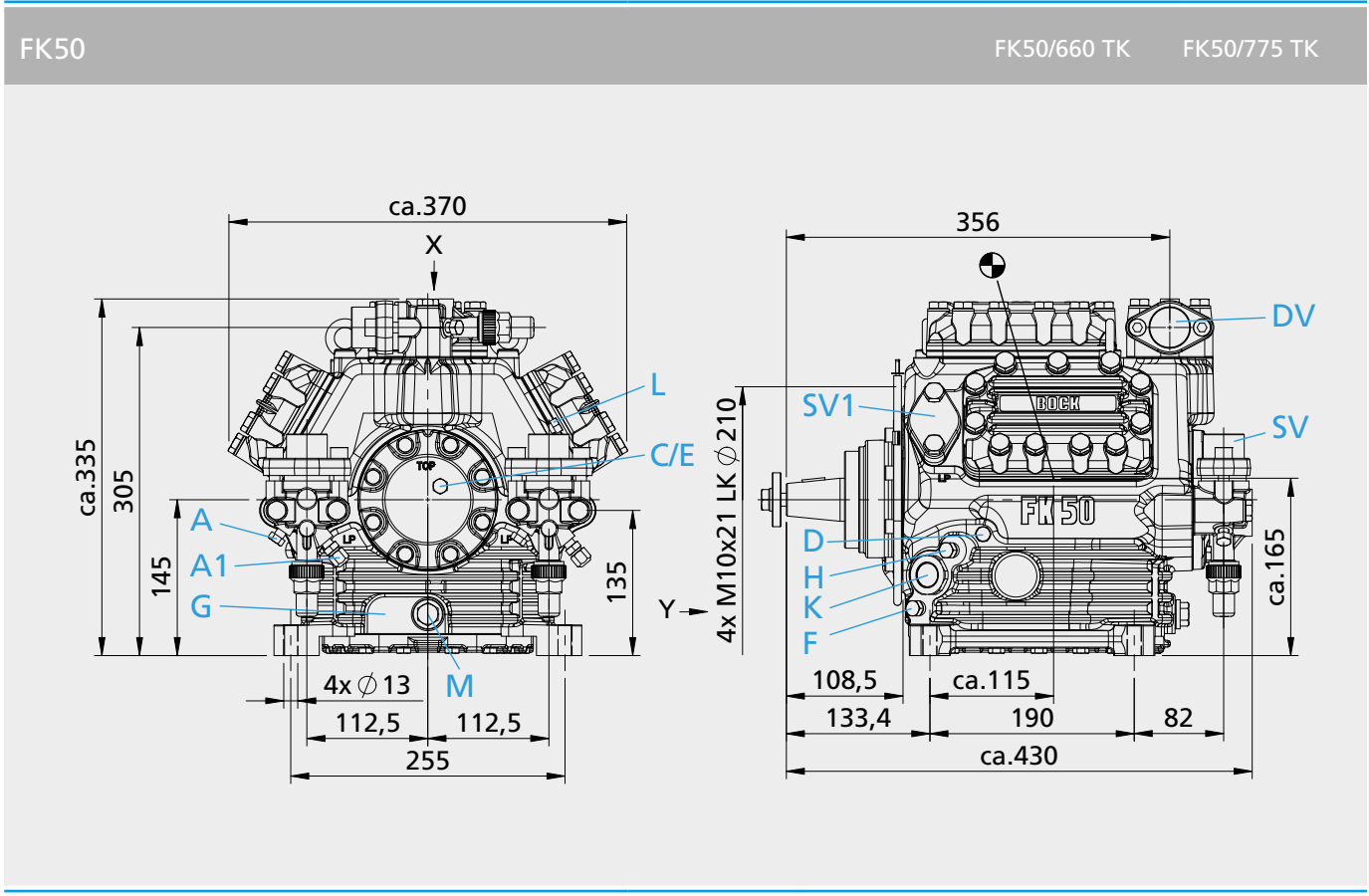

Connections	FK20	FK30	FK40	FK50
SV Suction line DV Discharge line	please refer to technical data page 36			
A Connection suction side, not lockable	7/16" UNF	7/16" UNF	1/8" NPTF	1/8" NPTF
A1 Connection suction side, lockable	7/16" UNF	7/16" UNF	7/16" UNF	7/16" UNF
A2 Connection suction side, not lockable	1/8" NPTF	1/8" NPTF	-	-
B Connection suction side, not lockable	7/16" UNF	7/16" UNF	1/8" NPTF	1/8" NPTF
B1 Connection discharge side, lockable	7/16" UNF	7/16" UNF	7/16" UNF	7/16" UNF
C Connection oil pressure safety switch OIL	-	1/8" NPTF	1/8" NPTF	1/8" NPTF
D Connection oil pressure safety switch LP	-	1/4" NPTF	1/8" NPTF	1/8" NPTF
E Connection oil pressure gauge	-	1/8" NPTF	1/8" NPTF	1/8" NPTF
F Oil drain	G 1/8"	M 22 x 1,5	1/4" NPTF	1/4" NPTF
G Optional connection oil sump heater	○ ¹⁾	○ ¹⁾	○ ¹⁾	○ ¹⁾
H Oil charge plug	1/4" NPTF	1/4" NPTF	1/4" NPTF	1/4" NPTF
K Sight glass	○ ²⁾	1 1/8" - 18 UNEF	2 x 1 1/8" - 18 UNEF	2 x 1 1/8" - 18 UNEF
L Connection thermal protection thermostat	○ ³⁾	1/8" NPTF	1/8" NPTF	1/8" NPTF
M Oil filter	-	M 22 x 1,5	M 22 x 1,5	M 22 x 1,5
SV1 Optional connection suction line valve	-	●	●	●

● Option available

○ Available on request

¹⁾ No connection available as standard (connection M 22 x 1,5)

²⁾ Standard is without sight glass (connection M 20 x 1)

³⁾ No connection available as standard (1/8" NPTF, intermediate flange required)

1
2
3
4
5
6
7
8

Dimensions with accessories

FK20 TK FK30 TK FK40 TK FK50 TK

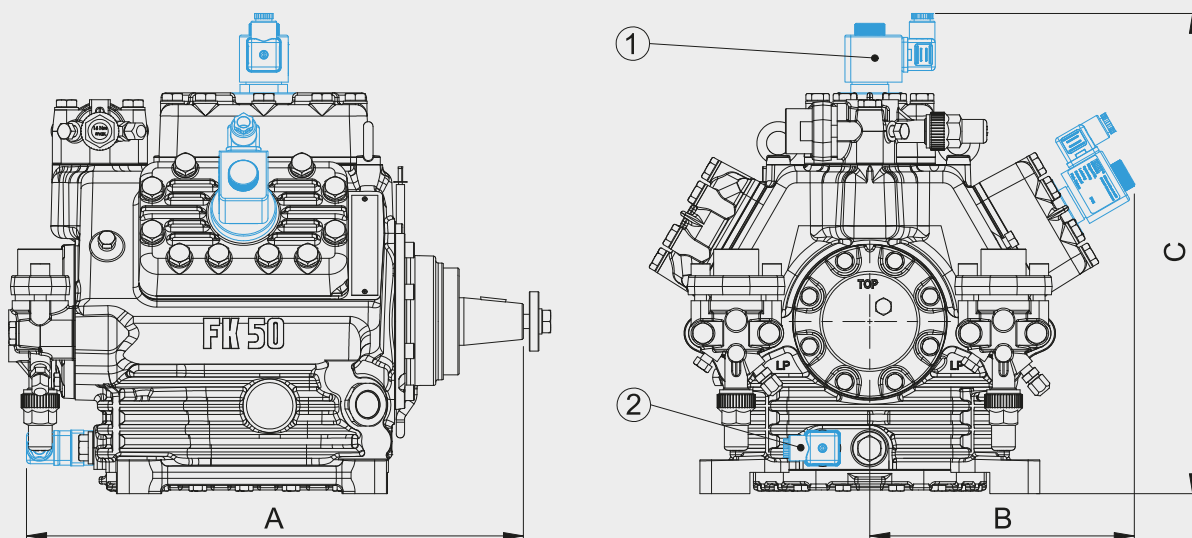

- ① Capacity regulator ② Oil sump heater

Type	A mm	B mm	C mm
FK20 TK	ca. 290	-	-
FK30 TK	ca. 355	-	-
FK40 TK	ca. 410	ca. 180	-
FK50 TK	-	ca. 225	ca. 405

Scope of supply	FK20	FK30	FK40	FK50
Open type compressor in a light aluminium construction, with suction and discharge valves	●	●	●	●
Two cylinder, cylinder arrangement in row	●	●		
Four cylinder, cylinder arrangement in V			●	
Six cylinder, cylinder arrangement in W				●
Integrated oil collecting system for the shaft seal, hose drain design		●	●	●
Seat front bearing flange		●	●	●
Fastening possibility for electromagnetic clutch	●	●	●	●
Oil charge: FK: FUCHS Reniso SP 46 FKX: FUCHS Reniso Triton SE 55	●	●	●	●
One sight glass		●		
Two sight glasses			●	●
Decompression valve		● ¹⁾	●	●
Inert gas charge	●	●	●	●

¹⁾ Only for models FK30/275 + 325

The scope of supply is the same for the various levels of displacement.

In the data concerning the type of compressor, these additions are not taken into account.

- 1
- 2
- 3
- 4
- 5
- 6
- 7
- 8

Accessories	FK20	FK30	FK40	FK50
① Capacity regulator 24 V DC, 8 W: 1 capacity regulator = 50 % residual capacity IP65 ¹⁾			●	
Capacity regulator 24 V DC, 8 W: 1-2 capacity regulator = 66 / 33 % residual capacity IP65 ¹⁾				●
② Electromagnetic clutch 24 V DC LA 21, Ø 147 mm, 2 x SPA, Power consumption 48 W ^{1) 2) 4)}	●			
Electromagnetic clutch 24 V DC LA 30,01, Ø 174 mm, 2 x SPA, Power consumption 51 W ^{1) 2) 4)}		●		
Electromagnetic clutch 24 V DC LA 16.028, Ø 153 mm, 2 x SPB, Power consumption 60 W ^{1) 2) 4)} to 775			●	●
③ Compressor flywheel (three-spoke, grey cast iron) Ø 165 mm, 2 x SPA	●			
Compressor flywheel (three-spoke, grey cast iron) Ø 210 mm, 2 x SPA		●		
Compressor flywheel (three-spoke, grey cast iron) Ø 210 mm, 3 x SPA			●	●
④ Oil sump heater 24 V DC, 40 W IP65 ¹⁾	●			
Oil sump heater 24 V DC, 80 W IP65 ¹⁾		●	●	●
⑤ Thermal protection thermostat (bimetal sensor) IP67	● ³⁾	●	●	●
⑥ Intermediate flange for changing the position of the shut-off valves ²⁾ Oval flange, height 5, 12, 15, 25, 34, 46, 62, 71, 75 oder 95 mm		●	●	●
Sight glass	● ⁵⁾			

¹⁾ Other voltages on request

²⁾ Other designs on request

³⁾ With intermediate flange

⁴⁾ Product by Linnig

⁵⁾ Possible just ex works, cannot be retrofitted

The accessories are the same for the various levels of displacement.
In the data concerning the type of compressor, these additions are not taken into account.

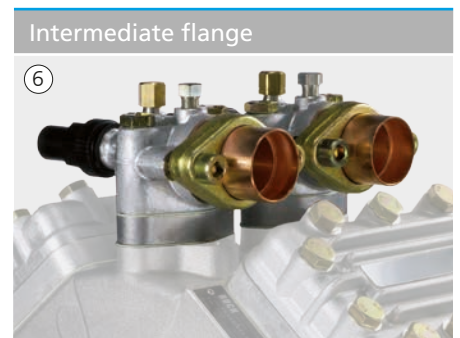
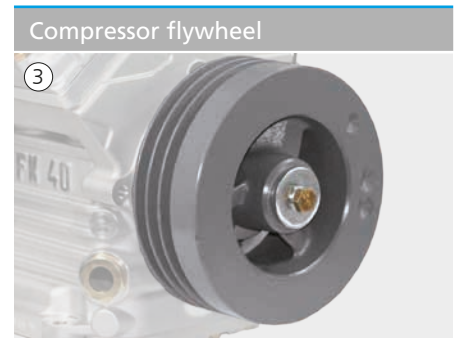
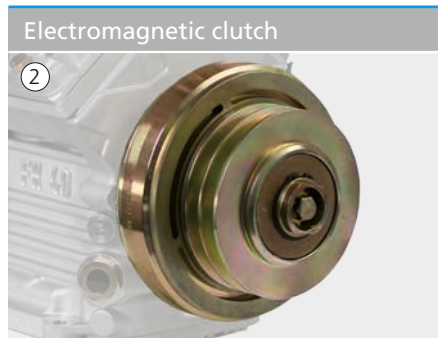

- 1
- 2
- 3
- 4
- 5
- 6
- 7
- 8

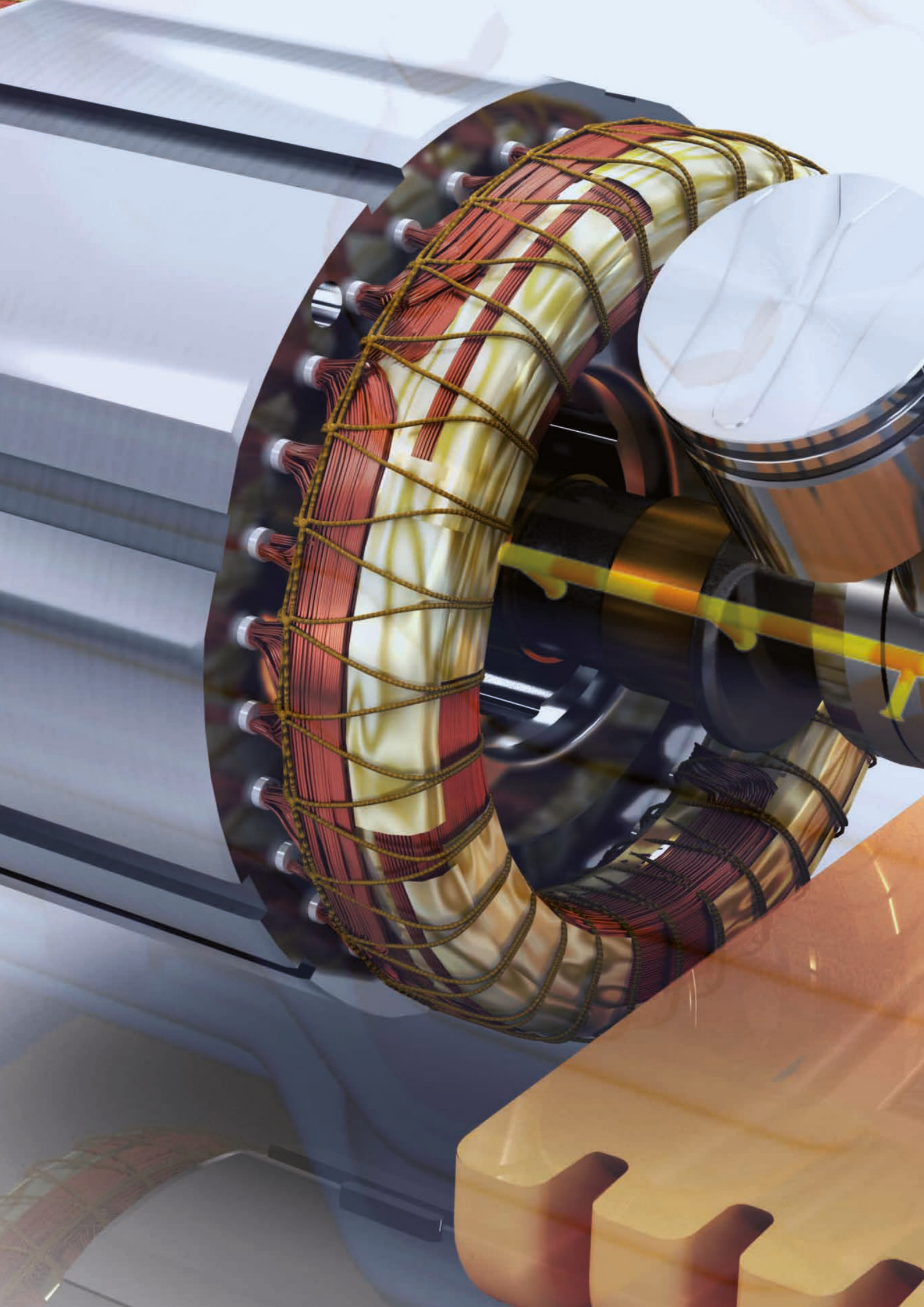



The difference is in the detail - Characteristics semi-hermetic Bock compressors

Special features	48
MP10 Motor Protection	51
Frequency converter technology	52
ESS Electronic Soft Start	53
e-series	54
Aluminium compressors	55
2-pole compressors	56

Universal

- e.g. R134a, R404A, R507, R407C, R22
- One compressor design for all standard refrigerants.
- For air-conditioning applications, normal refrigeration and deep-freezing
- Maximum allowed operating pressure (HP): 28 ba

High refrigeration capacity combined with minimum power requirement

- Optimized gas flow
- Efficient service valves
- Minimum clearance volume
- Powerful, economic drive motors

Stable valve plate design

- Universally proven valve design with intake and discharge finger reed valves clamped on one side
- Valve made of high quality impact-resistant spring steel

Replaceable motors

The compressors can be repaired in the field as the drive motor can be exchanged. (Not for 2-pole aluminium compressors).

Economic capacity control

- Cylinder cover incorporating a connection for capacity control
- Possible control stages:
 - 4 cylinder: 50 %

Minimum space requirement

Particularly low installation height and width

Quiet and low vibration

- Generously dimensioned crank mechanism
- Optimized mass balance
- Large volume pressure section for pulsation absorption
- 4 cylinder design from as little as 18,8 m³/h at 50 Hz

Safe, reliable oil supply

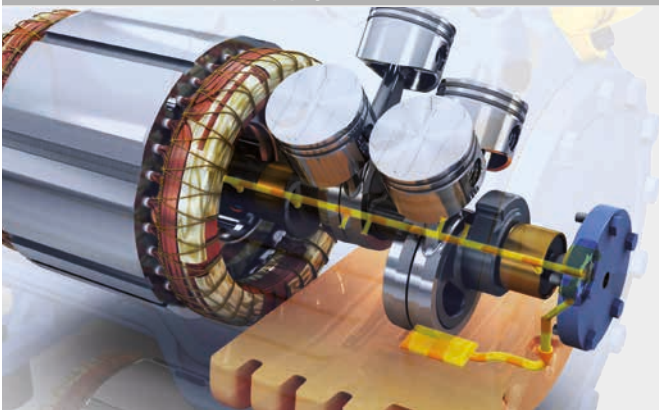

- Forced-feed lubrication independent of direction of rotation
- Large volume oil sump

Wear-resistant durable driving gear



- Solid construction and design
- Low friction sleeve bearings
- Aluminium pistons with two ring assembly

Solid construction and design

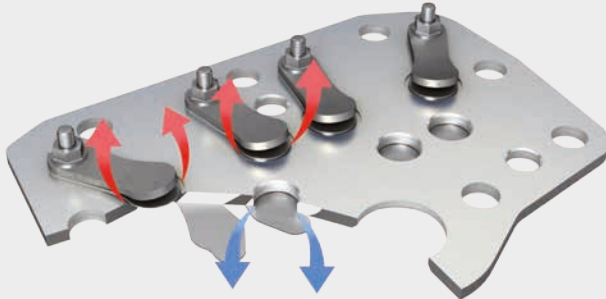

- Valve design, tried and trusted all over the world, with on-sided fixed finger reed, suction and pressure side
- Valve made of high quality impact-resistant spring steel

Replaceable motors

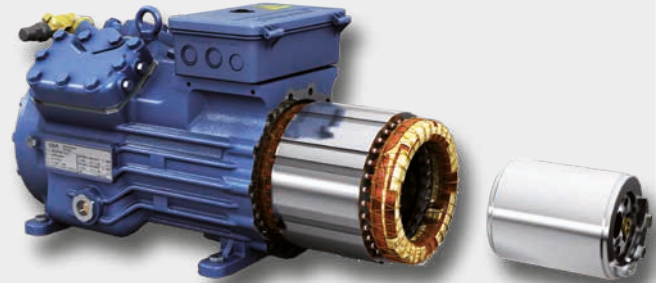

- The compressors can be repaired directly on-site, since the motors are replaceable.
- Only for grey cast iron housings and 4-pole aluminium compressors!

Variable suction line valve position



- Shut-off valves rotatable through 90°
- Flexible location for suction line and discharge line connection

Oil sump heater (option)

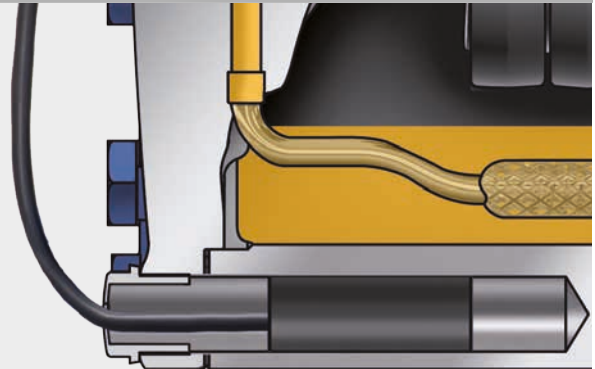

- Installed in the housing bore
- Replacement without opening the refrigeration circuit

Economic capacity control (option)

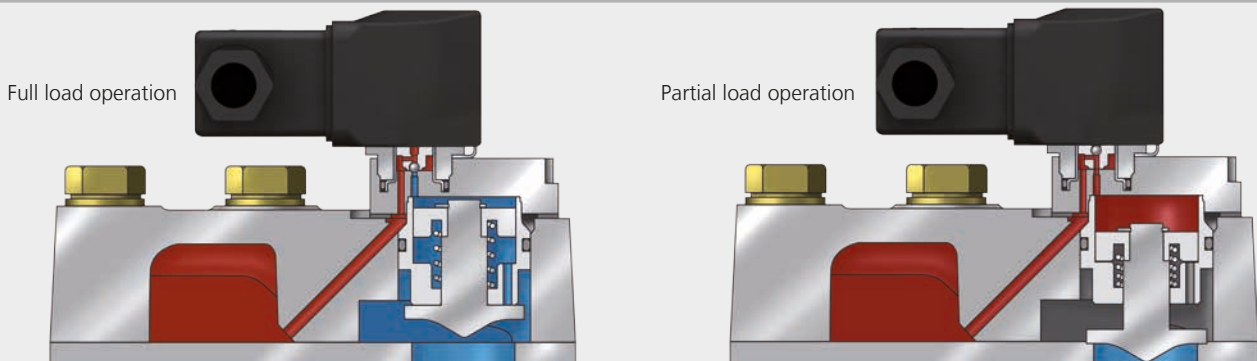

- Locking of suction port of a cylinder bank with an electromagnetic pilot valve
- Possible residual capacity:
4-cylinder compressor: 50 %

1
2
3
4
5
6
7
8

Electric switch box



- Robust aluminium construction
- Easy electrical installation due to large internal volume
- Terminal block with cables in glass seal model
- Hinged and removable lifting cover ① with a single quick fastener ②
- Terminal strip for add-on components
- Protection system: IP66

Electric switch box with reduced height (option)



- Terminal box with reduced height (-15 mm)
- Motor protection MP10 as an extra item for control cabinet installation

MP10 Motor Protection

Temperature safety drive for the drive motor

Technical data

Standard in all compressors

The exceptional feature is that the monitoring function and mains availability are shown by coloured LED's. There are no complicated or time-consuming defect locating processes.

Unit designation	MP10
Connection voltage	AC 230 V - 1 - 50/60 Hz
Relay	AC 250 V, 3 A, 750 VA ind.
Dimensions L/W/H	100 x 60 x 52 mm

The MP10 also provides the usual functions as standard, e.g. a reconnection preventing device, a reset, free terminals for PTC temperature sensors (e.g. heat protection thermostat) and other useful items.

- 1
- 2
- 3
- 4
- 5
- 6
- 7
- 8

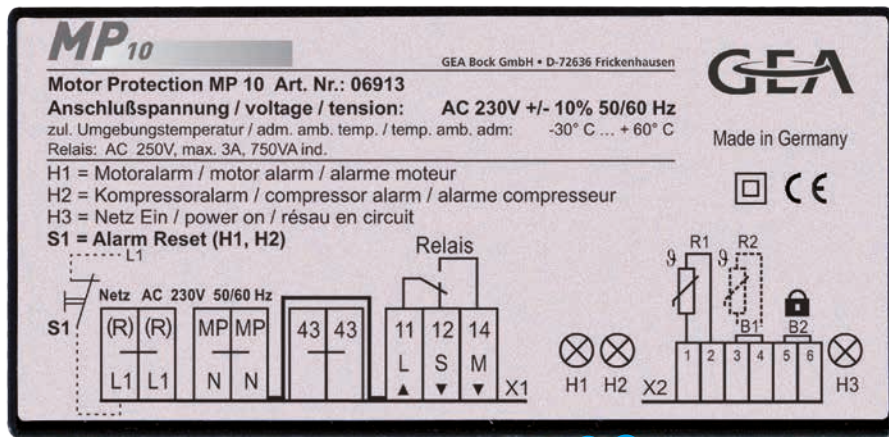

Supply section
Cable connections with screwless terminals

Green LED
Mains supply available

Red LED
Temperature fault in motor

Drive section
Cable connections with screwless terminals

Red LED
Temperature fault (random e.g. heat protection thermostat)

Continuously variable speed control using frequency converter technology

Continuously variable speed control using frequency converter technology is the most efficient means of adapting the capacity of the compressor to current refrigeration plant requirements.

Thanks to the oil pump lubrication all Bock compressors are ideal for speed control, in particular for low frequencies.

The advantages of frequency-converter operation:

- Fully variable adjustment of the refrigerating capacity on demand
- No high-energy, high-wear start/stop operation
- 25 % or more energy saving potential!
- Reduced mechanical compressor load for longer service life
- Always optimum machine pressures and operating conditions
- Lower pressure losses in the heat exchangers
- Lower cooling down and heating up losses throughout the system
- Reduced start-up current at full torque
- Part windings and star-delta circuits no longer required

Start-up current with and without EFC

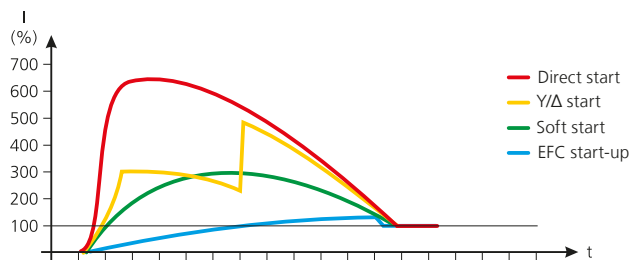

COP behaviour with EFC

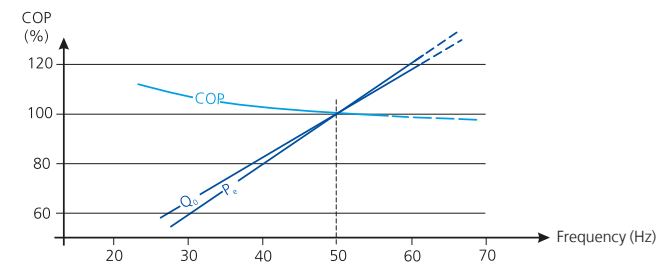

Engine performance factor with and without EFC

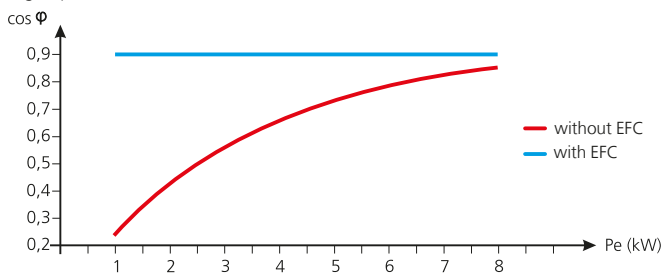

Start/stop behaviour with and without EFC

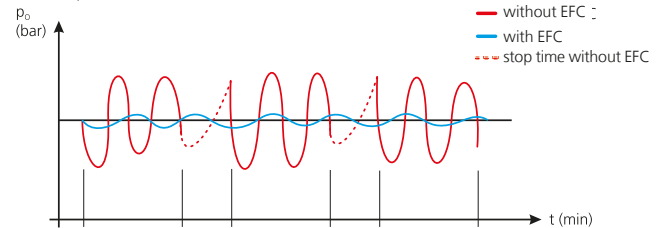

Calculations for 4-pole compressors

Calculating the maximum possible frequency of the compressor under specific operating conditions:

The following calculation is used to obtain the maximum possible frequency at the selected operating point:

$$f_{\max} = \frac{P_{\max} \times 50 \text{ Hz}}{P_e}$$

f_{\max} = Maximum permissible frequency [Hz]

P_{\max} = Maximum power consumption [kW] (see technical data)

P_e = Power consumption at the operating point at 50 Hz [kW] (see performance data, compressors)

Calculating the corresponding refrigerating capacity:

Refrigeration capacity can be determined as a function of frequency from the following calculation:

$$\dot{Q}_0 \text{ Betrieb} = \frac{f_{\text{Betrieb}} \times \dot{Q}_0 \text{ 50 Hz}}{50 \text{ Hz}}$$

$\dot{Q}_0 \text{ operation}$ = Refrigerating capacity at the chosen operating point [W]

$f_{\text{operation}}$ = Frequency at the chosen operating point [Hz]

$\dot{Q}_0 \text{ 50 Hz}$ = Refrigerating capacity at the operating point at Hz [W] (see performance data, compressors)



As a rule, the maximum permissible power consumption of the compressor P_{\max} must not be exceeded.

ESS System Electronic Soft Start

Electronic compressor starter unit

Available as option for:
HG22e, HG34e, HG34P

The start process uses an electronic soft start unit, instead of the conventional start unloader through the bypass solenoid valve, non-return valve and star-delta protector combination. This means that the compressor gets up to its nominal speed in a set time and therefore produces much lower power peaks than the classical star-delta start.

The unit is designed to fit into a switch cabinet.

Scope of supply:

- Unit suitable for fitting into a switch cabinet
- Voltage AC 400 V - 3 - 50/60 Hz
- Control voltage AC 230V - 1 - 50/60 Hz

The advantages:

- Soft compressor start from zero to nominal speed, time controlled and monitored.
- **Up to 40 % lower start-up power consumption than when using star-delta start**
- **No star-delta protection combination needed, no bypass between pressure and suction side needed. No solenoid valve or non-return valve needed**
- No compressor damage resulting from malfunction of the start unloader.

Dimensions

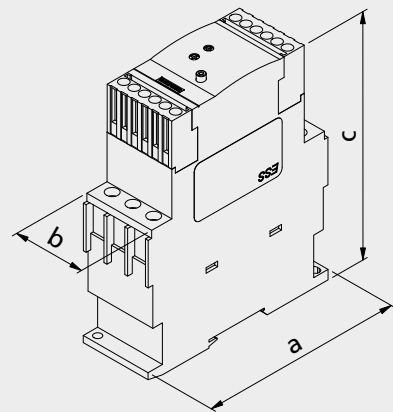

Technical data

Unit designation	Protection	Max. output current ¹⁾	Input	Lost heat	Dimensions a / b / c
ESS 25	IP 20 Connectors IP00	25 A	AC 400 V -3- 50/60 Hz	8 W	125 x 45 x 150
ESS 38		38 A		19 W	125 x 45 x 150
ESS 63		63 A		12 W	160 x 55 x 170

¹⁾ at +50 °C ambient temperature

e-series efficiency-optimized version

Based on our current semi-hermetic product range, with its outstanding advantages and features, GEA Bock presents you the e-series. Those compressors are efficiency optimised models for all standard refrigerants.

All compressors of the HG series will gradually be available as e-series.

Special features

With technical optimisations we improve the energy consumption of our compressors continuously. The compressors of the e-series set a new standard when it comes to motor-efficiency, gas flow and efficiency of the valve system. All this results in a higher capacity of the compressor.

Available models	Displacement 50 Hz (1.450 rpm)
HG22e/125-4 HG22e/125-4 S	11,1 m ³ /h
HG22e/160-4 HG22e/160-4 S	13,7 m ³ /h
HG22e/190-4 HG22e/190-4 S	16,5 m ³ /h
HG34e/215-4 HG34e/215-4 S	18,8 m ³ /h
HG34e/255-4 HG34e/255-4 S	22,1 m ³ /h
HG34e/315-4 HG34e/315-4 S	27,3 m ³ /h
HG34e/380-4 HG34e/380-4 S	33,1 m ³ /h

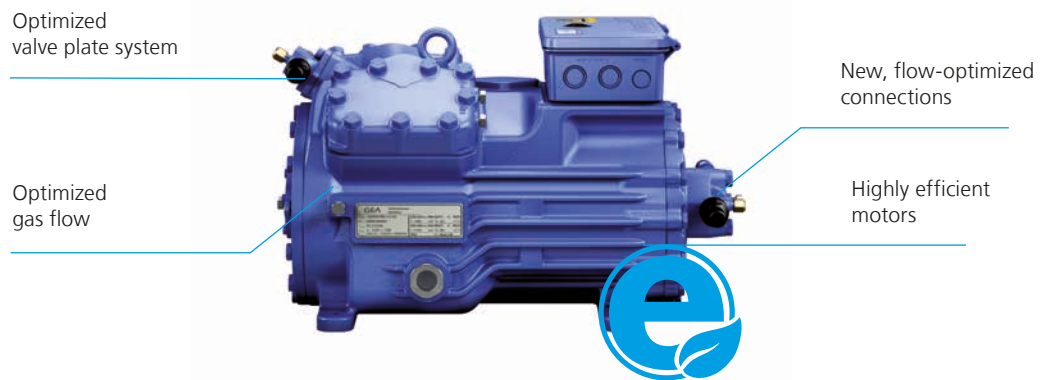

Powerful lightweights – semi-hermetic compressors for mobile applications

With the two models HG22 and HG34 in full-aluminium, lightweight construction, GEA Bock offers the perfect solution for all application areas in which the weight of the compressor is important.



Whether used in railway- or bus air-conditioning or transportation refrigeration – these compressors, which are around 40% lighter than standard compressors, offer system manufacturers new possibilities. Moreover, the compressors are available with a terminal box with reduced height, to be even more compact than the standard version.

For especially power-intensive applications, such as mobile air-conditioning, GEA Bock also offers the Pluscom model HG34P in 2-pole design.

The 2-pole drive motor generates a rotational speed of 2900 rpm (in comparison, 4-pole 1450 rpm) and so a high refrigeration capacity never before achieved in this size.

The HG34P in 2-pole design is available both in grey cast iron and in the above-mentioned aluminium lightweight design and reduced height terminal box.



- 1
- 2
- 3
- 4
- 5
- 6
- 7
- 8

Semi-hermetic compressors with 2-pole drive motor

Based on our compressors of the Pluscom series with its outstanding advantages and features, GEA Bock offers already for some time a compressor version with 2-pole drive. This compressor version now offers a mains frequency of 60 Hz and thus an increased refrigeration capacity compared to the operation with 50 Hz mains frequency.

This increase in the maximum possible compressor capacity can be realized through the use of a special valve plate system. The so-called Bock K-valve plate, which was developed by GEA Bock especially for mobile applications, is already used thousands of times in the area of bus air-conditioning and sets the international standard for quality and reliability.

Shall the compressor without a frequency converter operate at a power supply frequency of 50 Hz, the adaptation of the mains frequency is necessary.

e.g. 400 V / 50 Hz
460 V / 60 Hz

Available models	Displacement 50 Hz (2900 rpm)	Displacement 60 Hz (3480 rpm)
HGX34P/255-2 HGX34P/255-2 A	44,3 m ³ /h	-
HGX34P/315-2 HGX34P/315-2 A HGX34P/315-2 S HGX34P/315-2 S A	54,7 m ³ /h	-
HGX34P/315-2 A K HGX34P/315-2 S A K	54,7 m ³ /h	65,6 m ³ /h
HGX34P/380-2 HGX34P/380-2 A	66,1 m ³ /h	-
HGX34P/380-2 A K	66,1 m ³ /h	79,4 m ³ /h

Special features

- High performance with 2-pole drive motor (up to 3480 rpm)
- With oil pump lubrication as standard
- Bock K-valve plate
- Also available in aluminium lightweight design (option) (ca. 40% weight savings)
- Available with terminal box with reduced height

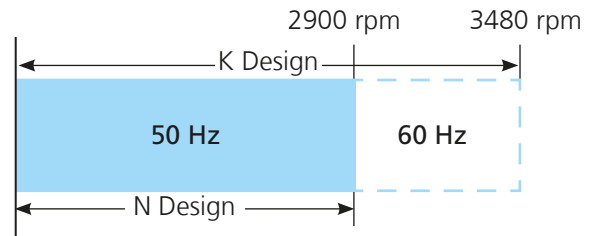

The K Design for 50 Hz and 60 Hz

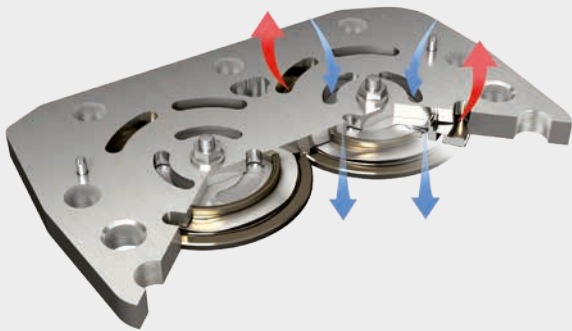

- The Bock K-valve plate with ringfins for higher loads

The N Design for 50 Hz

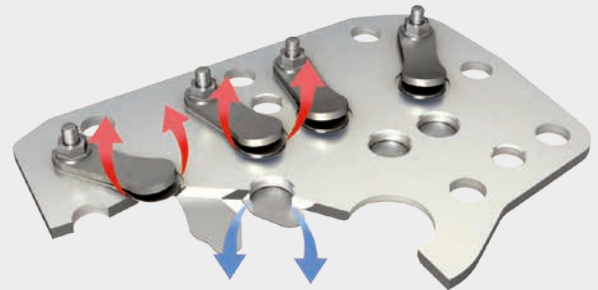

- Valve design, tried and trusted all over the world, with one-sided fixed finger reed valves, suction and pressure side
- Valve made out of high quality, impact resistant spring steel

1
2
3
4
5
6
7
8





Semi-hermetic Compressors for railway- and bus air-conditioning

At a glance	60
Operating limits and performance data	62
Technical data	69
Dimensions and connections	71
Scope of supply and accessories	76

Semi-hermetic 2- and 4-cylinder compressors in cast iron and full-aluminium construction

The Bock semi-hermetic compressor programme for mobile applications provides a full performance range of innovative and modern compressor designs in 2- and 4-cylinder constructions.

The ideal solution for any kind of mobile application.

Type key

HGX34P / 215 - 2 S A K

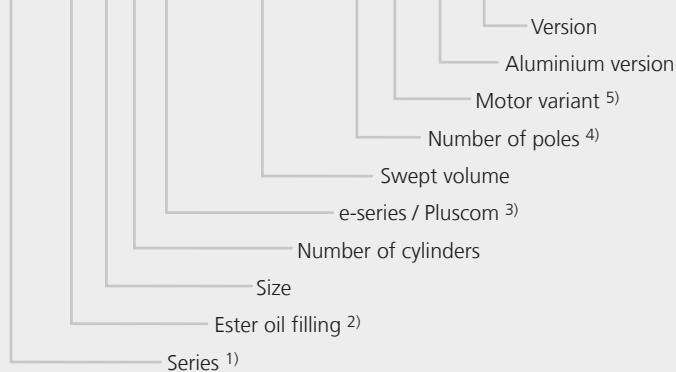

- 1) HG = Hermetic Gas-cooled (suction gas-cooled)
- 2) X = Ester oil filling (HFC refrigerant e.g. R134a, R407C)
- 3) = Additional indication for e-series and Pluscom compressors
- 4) 2 = 2-poles (2.900 rpm - 50 Hz)
4 = 4-poles (1.450 rpm - 50 Hz)
- 5) S = More powerful motor e.g. air-conditioning systems
- 6) K = K valve plate

The current program

...3 model sizes with 14 capacity stages

from 5,4 to 33,1 (1450 rpm) and 44,3 to 66,1 m³/h (2900 rpm)

2-pole



HG34

4-pole



HG34



HG22



HG12

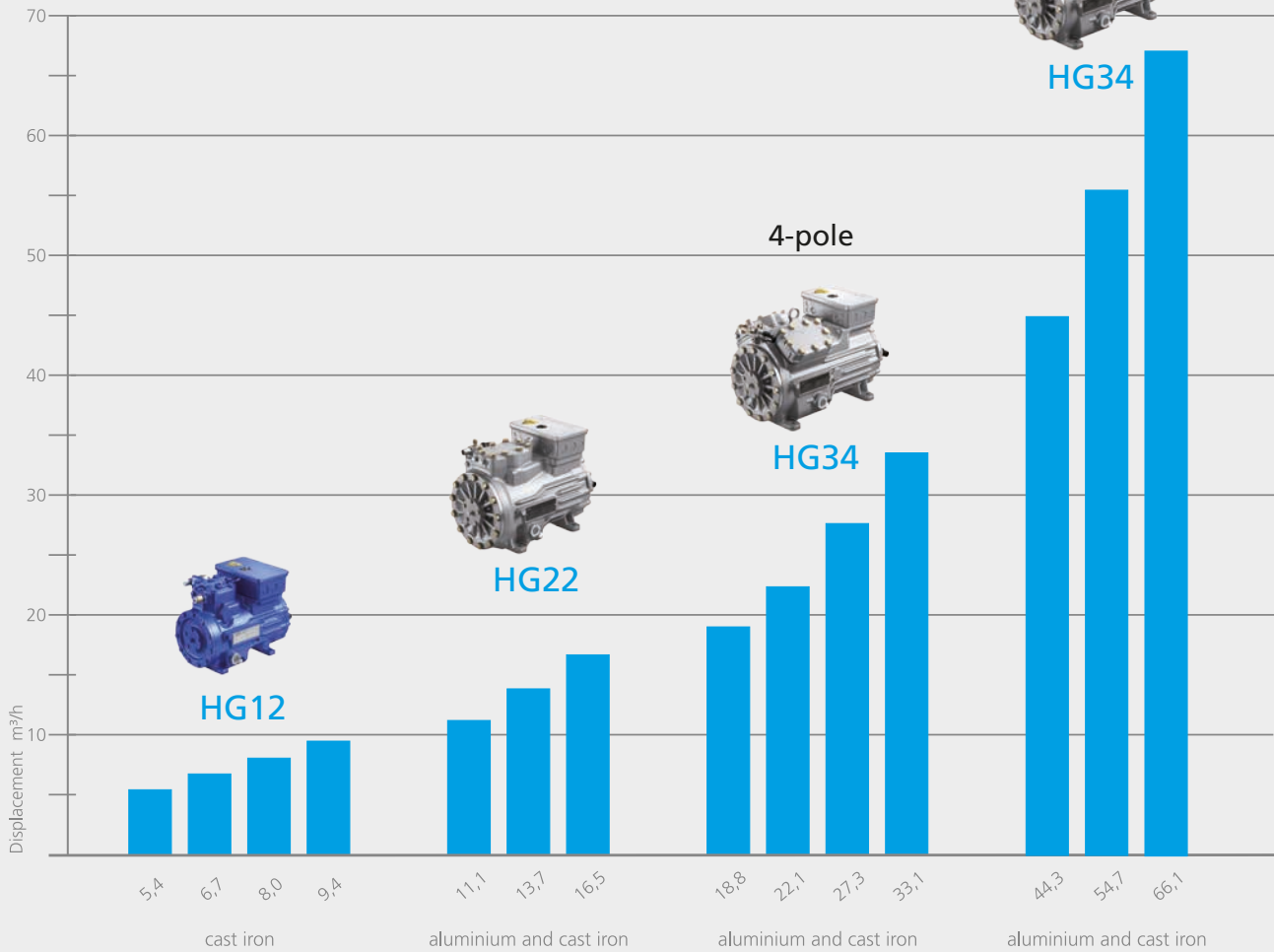

- 1
- 2
- 3
- 4
- 5
- 6
- 7
- 8

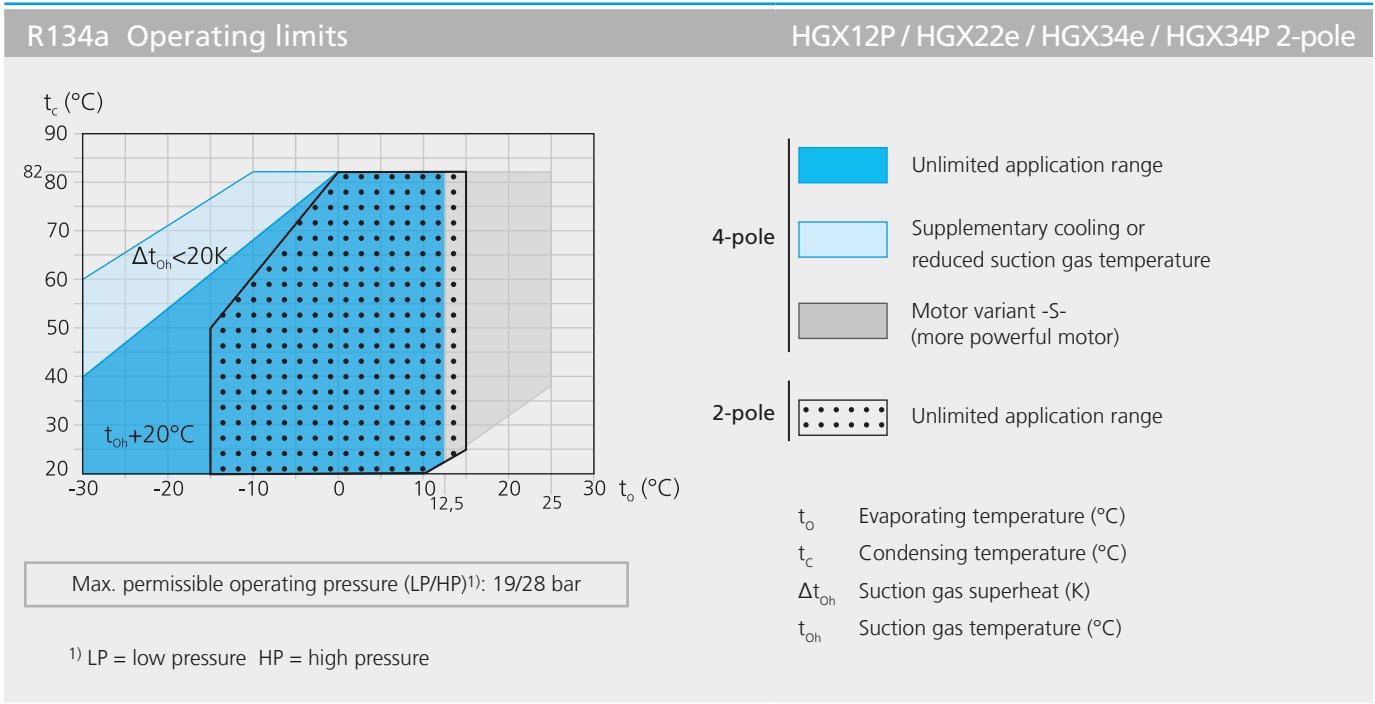

R134a Notes

Operating limits

Compressor operation is possible within the limits shown on the application diagrams. Please note the coloured areas. Compressor application limits should not be chosen for design purposes or continuous operation.

Restrictions to the operating limits may occur when using a capacity regulator.

Restrictions to the operating limits may occur when using a frequency converter. For further information see sample calculation page 52.

For operation with frequency converter:

- HGX12P...-4 30-70 Hz
- HGX22e...-4 30-70 Hz
- HGX34e...-4 25-70 Hz
- HGX34P...-2 15-50 Hz
- HGX34P...-2 K 15-60 Hz

Performance data

The performance data for R134a are based on EN 12900 at 50 Hz supply frequency. This signifies 20 °C suction gas temperature without liquid subcooling.

This results in significant differences compared to specifications with liquid undercooling and/or suction gas temperatures.

4-pole compressor:
 Conversion factor for 60 Hz = 1,2

Performance data for other operating points, see GEA Bock software.

ASERCOM certified performance data

For compressors with this label, the performance data are certified according to the strict requirements of ASERCOM.

ASERCOM is the Association of European Refrigeration Compressors and Controls Manufacturers.

Information about the Association and the constantly updated overview of certified Bock compressors can be found at www.asercom.org.

R134a		Performance data										50 Hz 4-pole			
Type	Cond. temp. °C	Q	Cooling capacity \dot{Q}_o [W]										Power consumption P [kW]		
			Evaporation temperature °C										-20	-25	-30
			12,5	10	7,5	5	0	-5	-10	-15					
HGX12P/60-4 S	30	Q	4920	4490	4080	3700	3010	2420	1910	1480	1130	836	605		
		P	0,70	0,71	0,71	0,71	0,68	0,65	0,60	0,54	0,49	0,44	0,40		
	40	Q	4260	3880	3520	3190	2590	2070 1	630	1250	932	670	456		
		P	0,85	0,84	0,83	0,81	0,77	0,71	0,65	0,59	0,54	0,49	0,45		
	50	Q	3630	3300	2990	2700	2190	1740	1350	1030	742	505	302		
	P	0,99	0,97	0,94	0,91	0,85	0,77	0,70	0,63	0,57	0,52	0,49			
	60	Q	3020	2740	2480	2240	1800	1420	1100	806	558	341	146		
		P	1,11	1,08	1,04	1,00	0,91	0,82	0,74	0,66	0,59	0,55	0,52		
	70	Q	2450	2220	2010	1810	1450	1130	847	602	381				
		P	1,22	1,17	1,12	1,06	0,96	0,85	0,75	0,66	0,60				
HGX12P/75-4 HGX12P/75-4 S	30	Q	6150	5610	5100	4620	3760	3020	2390	1850	1410	1050	756		
		P	0,88	0,89	0,89	0,88	0,85	0,81	0,75	0,68	0,61	0,55	0,50		
	40	Q	5320	4850	4400	3980	3230	2590	2030	1560	1170	837	569		
		P	1,06	1,05	1,03	1,01	0,96	0,89	0,82	0,74	0,67	0,61	0,57		
	50	Q	4530	4120	3730	3380	2730	2170	1690	1280	927	630	377		
	P	1,23	1,21	1,17	1,14	1,05	0,97	0,88	0,79	0,71	0,65	0,62			
	60	Q	3780	3430	3100	2800	2250	1780	1370	1010	697	425	182		
		P	1,39	1,35	1,30	1,24	1,13	1,02	0,92	0,82	0,74	0,68	0,65		
	70	Q	3070	2780	2510	2260	1800	1410	1060	751	476				
		P	1,53	1,46	1,40	1,33	1,19	1,06	0,94	0,83	0,74				
HGX12P/90-4 HGX12P/90-4 S	30	Q	7300	6670	6070	5520	4510	3630	2870	2230	1700	1260	912		
		P	1,08	1,10	1,12	1,12	1,10	1,06	1,00	0,92	0,83	0,74	0,65		
	40	Q	6380	5820	5290	4790	3890	3110	2440	1880	1410	1020	708		
		P	1,33	1,33	1,32	1,30	1,24	1,16	1,06	0,96	0,85	0,74	0,65		
	50	Q	5490	4990	4520	4080	3290	2610	2030	1540	1130	793	522		
	P	1,59	1,56	1,53	1,48	1,38	1,26	1,14	1,01	0,89	0,77	0,67			
	60	Q	4620	4180	3780	3400	2720	2140	1640	1230	876	592	359		
		P	1,82	1,77	1,71	1,65	1,51	1,35	1,20	1,05	0,91	0,79	0,69		
	70	Q	3780	3410	3060	2750	2180	1690	1280	937	653				
		P	2,00	1,93	1,84	1,76	1,58	1,40	1,22	1,05	0,90				
HGX12P/110-4 HGX12P/110-4 S	30	Q	8619	7858	7145	6477	5272	4231	3342	2593	1971	1464	1060		
		P	1,23	1,24	1,25	1,24	1,20	1,13	1,05	0,95	0,86	0,78	0,71		
	40	Q	7453	6787	6163	5580	4528	3619	2842	2183	1631	1173	797		
		P	1,49	1,48	1,45	1,42	1,35	1,25	1,14	1,04	0,94	0,85	0,79		
	50	Q	6342	5767	5229	4726	3820	3037	2364	1789	1299	883	528		
	P	1,74	1,70	1,65	1,60	1,48	1,36	1,23	1,11	1,00	0,92	0,87			
	60	Q	5287	4800	4344	3919	3152	2486	1910	1411	977	596	255		
		P	1,96	1,89	1,82	1,75	1,60	1,44	1,29	1,15	1,04	0,96	0,91		
	70	Q	4291	3888	3511	3159	2524	1969	1483	1053	667				
		P	2,15	2,06	1,96	1,87	1,68	1,49	1,31	1,16	1,04				
HGX22e/125-4 HGX22e/125-4 S HGX22e/125-4 A HGX22e/125-4 S A	30	Q	10200	9270	8440	7660	6220	4960	3860	2930	2160	1550	1090		
		P	1,30	1,35	1,38	1,39	1,39	1,34	1,25	1,14	1,02	0,891	0,765		
	40	Q	8990	8200	7450	6740	5440	4300	3310	2480	1790	1260	860		
		P	1,69	1,70	1,69	1,67	1,59	1,48	1,35	1,20	1,05	0,903	0,769		
	50	Q	7800	7090	6420	5780	4630	3620	2750	2020	1440	978	657		
	P	2,02	1,98	1,94	1,88	1,75	1,59	1,41	1,24	1,06	0,908	0,773			
	60	Q	6570	5950	5360	4810	3810	2940	2200	1590	1110	744	504		
		P	2,27	2,21	2,13	2,04	1,86	1,66	1,45	1,25	1,07	0,909	0,783		
	70	Q	5330	4800	4310	3840	3000	2280	1690	1200	829				
		P	2,48	2,38	2,27	2,16	1,93	1,70	1,47	1,25	1,06				
HGX22e/160-4 HGX22e/160-4 S HGX22e/160-4 A HGX22e/160-4 S A	30	Q	12800	11600	10600	9560	7780	6240	4920	3810	2870	2110	1490		
		P	1,63	1,65	1,66	1,65	1,63	1,59	1,51	1,41	1,29	1,15	0,983		
	40	Q	11200	10200	9200	8330	6750	5390	4230	3240	2410	1730	1160		
		P	2,07	2,05	2,03	2,00	1,92	1,81	1,68	1,53	1,36	1,17	0,962		
	50	Q	9640	8760	7930	7170	5780	4580	3560	2680	1940	1310	783		
	P	2,46	2,41	2,36	2,29	2,15	1,99	1,80	1,60	1,38	1,14	0,884			
	60	Q	8230	7460	6730	6060	4840	3790	2880	2100	1430	844	335		
		P	2,80	2,72	2,63	2,54	2,33	2,11	1,87	1,61	1,34	1,04	0,744		
	70	Q	6880	6210	5580	4990	3930	3000	2190	1490	862				
		P	3,09	2,97	2,85	2,72	2,45	2,17	1,87	1,56	1,23				

- 1
- 2
- 3
- 4
- 5
- 6
- 7
- 8

Relating to 20 °C suction gas temperature, without liquid subcooling

 Supplementary cooling or reduced suction gas temp.

R134a		Performance data											50 Hz 4-pole		
Type	Cond. temp. °C	Q/P	Cooling capacity \dot{Q}_o [W]										Power consumption P [kW]		
			Evaporation temperature °C												
			12,5	10	7,5	5	0	-5	-10	-15	-20	-25	-30		
HGX22e/190-4 HGX22e/190-4 S HGX22e/190-4 A HGX22e/190-4 S A	30	Q	15300	14000	12900	11700	9630	7800	6180	4790	3610	2640	1870		
		P	2,04	2,06	2,06	2,05	2,00	1,92	1,80	1,65	1,48	1,29	1,09		
	40	Q	13600	12500	11400	10400	8460	6810	5360	4110	3060	2200	1530		
		P	2,62	2,55	2,51	2,46	2,33	2,17	1,98	1,78	1,57	1,34	1,11		
	50	Q	11900	10800	9840	8940	7270	5800	4520	3430	2520	1790	1220		
		P	3,09	3,01	2,92	2,83	2,62	2,39	2,14	1,89	1,63	1,37	1,12		
60	Q	10100	9160	8320	7520	6070	4800	3700	2770	2010	1410	959			
	P	3,54	3,41	3,28	3,14	2,86	2,56	2,26	1,96	1,66	1,37	1,10			
70	Q	8280	7510	6790	6110	4880	3810	2900	2150	1540					
	P	3,91	3,74	3,57	3,39	3,03	2,68	2,32	1,97	1,64					
HGX34e/215-4 HGX34e/215-4 S HGX34e/215-4 A HGX34e/215-4 S A	30	Q	17200	15700	14400	13000	10600	8450	6590	5000	3670	2610	1800		
		P	2,27	2,30	2,32	2,31	2,25	2,14	1,98	1,80	1,59	1,38	1,18		
	40	Q	15200	13800	12600	11400	9120	7190	5530	4120	2970	2060	1400		
		P	2,87	2,84	2,78	2,72	2,55	2,34	2,11	1,87	1,64	1,42	1,22		
	50	Q	13000	11800	10700	9540	7590	5890	4440	3240	2270	1540	1040		
		P	3,38	3,27	3,16	3,03	2,76	2,47	2,18	1,90	1,64	1,42	1,24		
60	Q	10800	9690	8690	7750	6070	4620	3400	2420	1660	1120	784			
	P	3,79	3,62	3,45	3,27	2,90	2,54	2,20	1,89	1,61	1,39	1,24			
70	Q	8590	7680	6830	6040	4630	3440	2480	1730	1190					
	P	4,12	3,89	3,66	3,43	2,99	2,56	2,17	1,84	1,56					
HGX34e/255-4 ¹⁾ HGX34e/255-4 S HGX34e/255-4 A HGX34e/255-4 S A	30	Q	20600	18800	17200	15600	12700	10100	7800	5890	4320	3080	2190		
		P	2,61	2,67	2,71	2,71	2,66	2,53	2,34	2,12	1,88	1,63	1,41		
	40	Q	18100	16500	15000	13600	11000	8660	6660	4960	3570	2490	1710		
		P	3,36	3,35	3,31	3,25	3,08	2,84	2,57	2,27	1,97	1,68	1,43		
	50	Q	15600	14200	12900	11600	9310	7280	5540	4070	2880	1960	1330		
		P	4,02	3,93	3,83	3,71	3,42	3,08	2,73	2,36	2,01	1,68	1,41		
60	Q	13100	11900	10700	9610	7640	5920	4450	3220	2240	1510	1030			
	P	4,56	4,41	4,24	4,06	3,66	3,23	2,80	2,37	1,96	1,61	1,32			
70	Q	10500	9430	8480	7590	5970	4570	3380	2410	1660					
	P	4,98	4,77	4,54	4,30	3,79	3,28	2,76	2,28	1,83					
HGX34e/315-4 ¹⁾ HGX34e/315-4 S HGX34e/315-4 A HGX34e/315-4 S A	30	Q	25500	23300	21100	19200	15500	12400	9660	7390	5520	4040	2920		
		P	3,40	3,43	3,43	3,40	3,29	3,11	2,88	2,61	2,32	2,02	1,72		
	40	Q	22300	20300	18500	16700	13500	10700	8260	6260	4620	3320	2330		
		P	4,22	4,17	4,10	4,01	3,78	3,49	3,16	2,80	2,43	2,07	1,73		
	50	Q	19200	17400	15800	14200	11400	8950	6880	5140	3720	2600	1740		
		P	4,97	4,85	4,71	4,55	4,19	3,79	3,36	2,91	2,47	2,04	1,65		
60	Q	16100	14600	13100	11800	9350	7280	5520	4050	2850	1900	1170			
	P	5,63	5,44	5,22	5,00	4,51	4,00	3,46	2,93	2,41	1,92	1,47			
70	Q	13100	11800	10600	9390	7380	5660	4200	3000	2010					
	P	6,18	5,91	5,62	5,33	4,71	4,08	3,44	2,82	2,22					
HGX34e/380-4 ¹⁾ HGX34e/380-4 S HGX34e/380-4 A HGX34e/380-4 S A	30	Q	30700	28100	25600	23200	19000	15300	12100	9310	7060	5250	3860		
		P	4,27	4,28	4,26	4,22	4,06	3,83	3,53	3,20	2,83	2,46	2,09		
	40	Q	27000	24600	22400	20300	16600	13300	10400	8000	6020	4420	3180		
		P	5,26	5,19	5,09	4,97	4,67	4,30	3,89	3,46	3,00	2,56	2,13		
	50	Q	23200	21200	19300	17400	14100	11300	8760	6670	4940	3540	2450		
		P	6,17	6,01	5,83	5,63	5,18	4,69	4,16	3,62	3,07	2,55	2,06		
60	Q	19600	17800	16100	14600	11700	9240	7130	5350	3860	2650	1690			
	P	6,97	6,73	6,46	6,18	5,59	4,96	4,31	3,66	3,02	2,42	1,86			
70	Q	16000	14500	13100	11800	9340	7290	5530	4040	2800					
	P	7,65	7,31	6,97	6,60	5,86	5,09	4,32	3,56	2,83					

Relating to 20 °C suction gas temperature, without liquid subcooling

¹⁾ Compressors are ASERCOM certified



Supplementary cooling or reduced suction gas temp.

R134a		Performance data								50 Hz 2-pole
Type	Cond. temp. °C	Cooling capacity \dot{Q}_0 [W]						Power consumption P [kW]		
		Evaporation temperature °C								
		15	10	7,5	5	0	-5	-10	-15	
HGX34P/255-2 HGX34P/255-2 A	30	Q	39699	32887	29809	26941	21802	17406	13692	10598
		P	8,45	7,93	7,64	7,35	6,72	6,06	5,39	4,73
	40	Q	35067	28934	26166	23588	18969	15013	11659	8846
		P	9,53	8,81	8,43	8,05	7,25	6,45	5,65	4,86
	50	Q	30304	24875	22429	20153	16077	12585	9615	7106
P		10,40	9,49	9,03	8,56	7,62	6,68	5,76	4,87	
60	Q	25473	20771	18659	16696	13188	10184	7622		
	P	11,05	9,97	9,42	8,88	7,80	6,74	5,72		
70	Q	20632	16682	14916	13279	10362	7869			
	P	11,46	10,22	9,61	9,00	7,79	6,63			
HGX34P/315-2 HGX34P/315-2 A HGX34P/315-2 A K	30	Q	49386	40993	37189	33638	27263	21812	17227	13450
		P	8,65	8,62	8,51	8,34	7,86	7,24	6,52	5,75
	40	Q	43240	35838	32488	29362	23754	18957	14914	11567
		P	10,52	10,14	9,87	9,55	8,79	7,92	6,99	6,04
	50	Q	37096	30698	27807	25113	20284	16154	12665	9760
P		12,03	11,34	10,92	10,47	9,47	8,39	7,28	6,19	
60	Q	30994	25612	23187	20930	16893	13441	10519		
	P	13,20	12,23	11,69	11,12	9,91	8,66	7,41		
70	Q	24974	20620	18667	16854	13620	10860			
	P	14,04	12,83	12,18	11,51	10,14	8,75			
HGX34P/380-2 HGX34P/380-2 A HGX34P/380-2 A K	30	Q	54230	45243	41160	37338	30436	24457	19322	14952
		P	13,28	12,00	11,41	10,86	9,81	8,83	7,88	6,92
	40	Q	48142	40109	36453	33023	26803	21371	16647	12551
		P	14,18	12,89	12,28	11,68	10,54	9,42	8,28	7,09
	50	Q	41930	34842	31607	28565	23018	18124	13801	9971
P		15,17	13,79	13,12	12,46	11,15	9,81	8,42	6,93	
60	Q	35602	29450	26632	23973	19091	14724	10794		
	P	16,15	14,61	13,85	13,08	11,53	9,91	8,19		
70	Q	29169	23944	21538	19257	15030	11182			
	P	16,99	15,23	14,34	13,44	11,57	9,60			

R134a		Performance data								60 Hz 2-pole
Type	Cond. temp. °C	Cooling capacity \dot{Q}_0 [W]						Power consumption P [kW]		
		Evaporation temperature °C								
		15	10	7,5	5	0	-5	-10	-15	
HGX34P/315-2 A K	30	Q	55162	45788	41539	37572	30452	24363	19242	15024
		P	10,43	10,39	10,26	10,06	9,48	8,73	7,86	6,93
	40	Q	48298	40030	36288	32797	26533	21175	16659	12920
		P	12,69	12,23	11,90	11,51	10,60	9,55	8,43	7,29
	50	Q	41435	34289	31060	28050	22657	18043	14146	10902
P		14,51	13,67	13,17	12,62	11,42	10,12	8,78	7,47	
60	Q	34619	28607	25899	23379	18869	15014	11750		
	P	15,91	14,75	14,09	13,41	11,95	10,44	8,94		
70	Q	27895	23031	20850	18825	15213	12130			
	P	16,93	15,47	14,69	13,89	12,23	10,55			
HGX34P/380-2 A K	30	Q	60573	50535	45975	41705	33996	27318	21582	16701
		P	16,02	14,47	13,77	13,09	11,83	10,65	9,50	8,34
	40	Q	53773	44801	40717	36885	29938	23871	18594	14020
		P	17,10	15,54	14,81	14,09	12,71	11,36	9,98	8,55
	50	Q	46834	38917	35304	31906	25711	20243	15415	11137
P		18,30	16,63	15,83	15,03	13,45	11,83	10,15	8,36	
60	Q	39766	32895	29748	26777	21324	16446	12056		
	P	19,47	17,62	16,70	15,78	13,90	11,95	9,88		
70	Q	32581	26745	24057	21510	16788	12490			
	P	20,49	18,37	17,29	16,20	13,95	11,57			

Relating to 20 °C suction gas temperature,
without liquid subcooling

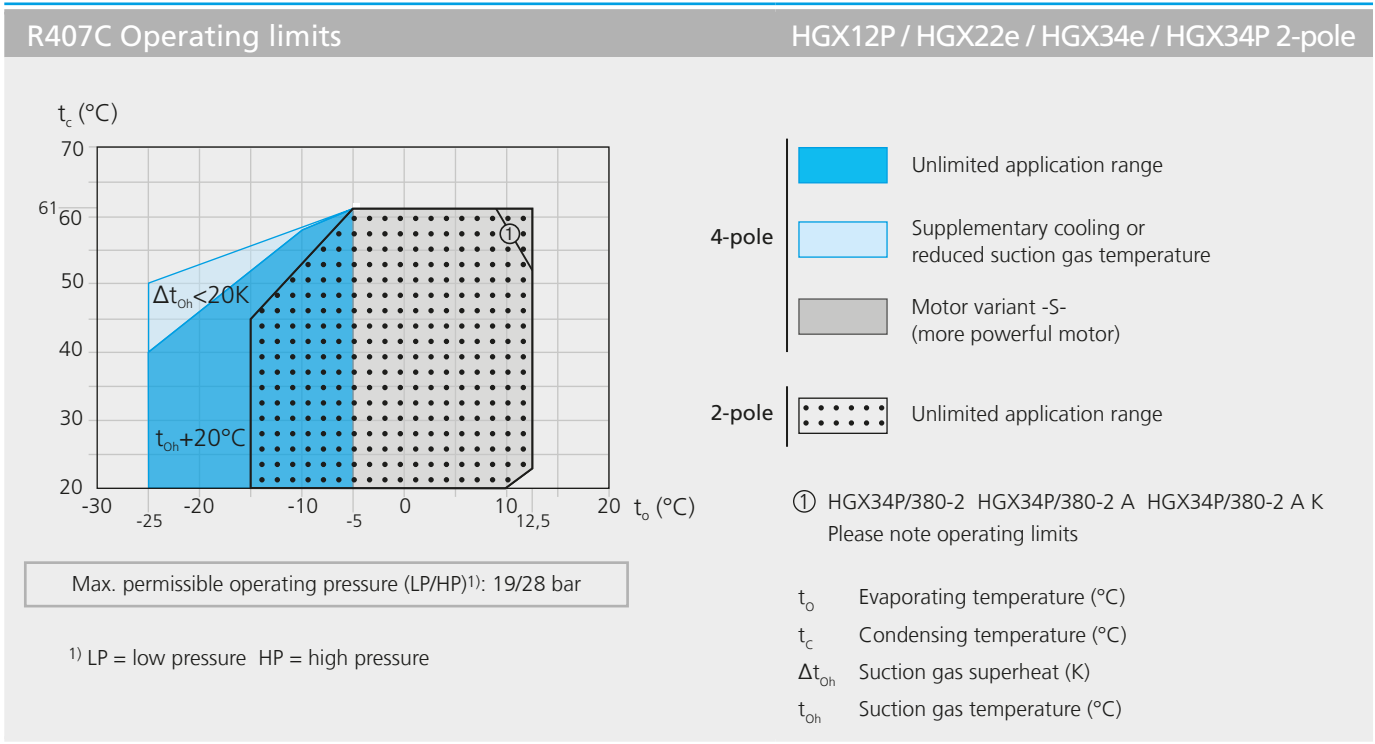

R407C Notes

Operating limits

Compressor operation is possible within the limits shown on the application diagrams. Please note the coloured areas. Compressor application limits should not be chosen for design purposes or continuous operation.

Restrictions to the operating limits may occur when using a capacity regulator.

Restrictions to the operating limits may occur when using a frequency converter. For further information see sample calculation page 52.

For operation with frequency converter:

HGX12P...-4 30-70 Hz
 HGX22e...-4 30-70 Hz
 HGX34e...-4 25-70 Hz
 HGX34P...-2 15-50 Hz
 HGX34P...-2 K 15-60 Hz

Performance data

The performance data R407C are based on EN 12900 to 50 Hz supply frequency. This signifies 20 °C suction gas temperature without liquid subcooling.

The evaporating- and condensing temperatures are based on the dew point values (saturated vapour conditions).

This results in significant differences compared to specifications with liquid undercooling and/or suction gas temperatures.

4-pole compressor:
 Conversion factor for 60 Hz = 1,2

Performance data for other operating points, see GEA Bock software.

R407C		Performance data										50 Hz 4-pole		
Type	Cond. temp. °C		Cooling capacity \dot{Q}_0 [W]								Power consumption P [kW]			
			Evaporation temperature °C											
			12,5	10	7,5	5	0	-5	-10	-15	-20	-25		
HGX12P/60-4 S	30	Q	6780	6180	5610	5080	4140	3330	2650	2080	1610	1230		
		P	0,88	0,90	0,92	0,92	0,91	0,88	0,82	0,76	0,69	0,62		
	40	Q	5870	5340	4840	4380	3560	2860	2270	1780	1360	1020		
P		1,16	1,16	1,15	1,13	1,08	1,01	0,92	0,83	0,74	0,66			
50	Q	5010	4550	4120	3720	3020	2420	1920	1490	1130	827			
	P	1,41	1,39	1,35	1,31	1,22	1,12	1,00	0,90	0,79	0,69			
HGX12P/75-4 HGX12P/75-4 S	30	Q	8740	7960	7230	6550	5340	4300	3420	2680	2080	1580		
		P	1,12	1,16	1,18	1,18	1,17	1,13	1,06	0,98	0,89	0,79		
	40	Q	7560	6880	6240	5650	4590	3690	2920	2290	1760	1320		
P		1,50	1,49	1,48	1,46	1,39	1,30	1,19	1,07	0,96	0,84			
50	Q	6450	5860	5310	4800	3890	3120	2470	1920	1460	1070			
	P	1,82	1,79	1,74	1,69	1,58	1,44	1,29	1,15	1,01	0,89			
HGX12P/90-4 HGX12P/90-4 S	30	Q	10500	9490	8620	7810	6360	5120	4080	3200	2480	1890		
		P	1,34	1,38	1,40	1,41	1,40	1,34	1,26	1,16	1,05	0,95		
	40	Q	9020	8200	7440	6730	5470	4400	3490	2730	2090	1570		
P		1,79	1,78	1,77	1,74	1,66	1,55	1,42	1,28	1,13	1,00			
50	Q	7690	6990	6330	5720	4640	3720	2940	2290	1740	1280			
	P	2,17	2,13	2,08	2,02	1,88	1,72	1,55	1,37	1,21	1,06			
HGX12P/110-4 HGX12P/110-4 S	30	Q	12300	11200	10200	9180	7480	6020	4790	3760	2910	2220		
		P	1,58	1,62	1,65	1,66	1,64	1,58	1,48	1,37	1,24	1,11		
	40	Q	10600	9640	8750	7910	6430	5170	4100	3200	2460	1850		
P		2,10	2,10	2,08	2,05	1,95	1,82	1,67	1,50	1,33	1,18			
50	Q	9040	8210	7440	6730	5460	4370	3460	2690	2040	1500			
	P	2,56	2,51	2,45	2,38	2,21	2,02	1,82	1,61	1,42	1,25			
HGX22e/125-4 HGX22e/125-4 S HGX22e/125-4 A HGX22e/125-4 S A	30	Q	14400	13100	11900	10800	8790	7070	5630	4420	3420	2600		
		P	1,78	1,82	1,85	1,87	1,85	1,78	1,67	1,53	1,39	1,25		
	40	Q	12500	11400	10300	9300	7560	6060	4800	3760	2890	2160		
P		2,36	2,35	2,33	2,30	2,19	2,04	1,87	1,68	1,5	1,32			
50	Q	10700	9640	8740	7910	6410	5120	4050	3150	2400	1760			
	P	2,87	2,81	2,75	2,67	2,48	2,27	2,04	1,81	1,59	1,40			
HGX22e/160-4 HGX22e/160-4 S HGX22e/160-4 A HGX22e/160-4 S A	30	Q	17600	16000	14500	13200	10700	8730	6950	5470	4240	3230		
		P	2,18	2,24	2,28	2,30	2,27	2,30	2,16	1,99	1,79	1,61		
	40	Q	15200	13800	12500	11300	9180	7500	5950	4650	3580	2680		
P		2,90	2,90	2,87	2,83	2,69	2,64	2,42	2,18	1,94	1,72			
50	Q	12900	11700	10700	9590	7780	6350	5020	3900	2970	2180			
	P	3,53	3,46	3,38	3,28	3,05	2,93	2,64	2,34	2,06	1,81			
HGX22e/190-4 HGX22e/190-4 S HGX22e/190-4 A HGX22e/190-4 S A	30	Q	21800	19900	18100	16400	13300	10800	8550	6700	5180	3960		
		P	2,67	2,74	2,79	2,81	2,78	2,83	2,65	2,44	2,20	1,98		
	40	Q	18900	17200	15600	14100	11500	9220	7310	5710	4390	3290		
P		3,54	3,54	3,51	3,46	3,29	3,25	2,97	2,68	2,38	2,10			
50	Q	16100	14600	13300	12000	9700	7790	6170	4810	3650	2670			
	P	4,31	4,23	4,13	4,01	3,73	3,60	3,24	2,87	2,53	2,22			
HGX34e/215-4 HGX34e/215-4 S HGX34e/215-4 A HGX34e/215-4 S A	30	Q	25600	23300	21100	19100	15600	12200	9720	7650	5910	4480		
		P	3,45	3,49	3,50	3,48	3,39	3,16	2,94	2,67	2,38	2,09		
	40	Q	22400	20300	18400	16600	13400	10400	8190	6410	4920	3700		
P		4,38	4,33	4,26	4,17	3,94	3,60	3,25	2,89	2,52	2,17			
50	Q	19100	17300	15600	14100	11300	8590	6820	5330	4100	3100			
	P	5,19	5,06	4,91	4,75	4,39	3,98	3,54	3,09	2,66	2,27			
HGX34e/255-4 HGX34e/255-4 S HGX34e/255-4 A HGX34e/255-4 S A	30	Q	29600	27000	24600	22300	18300	14500	11500	9040	7030	5300		
		P	4,30	4,30	4,28	4,23	4,08	3,84	3,54	3,20	2,85	2,48		
	40	Q	26000	23600	21500	19500	15800	12300	9730	7660	5940	4430		
P		5,33	5,24	5,13	5,00	4,71	4,38	3,94	3,50	3,06	2,63			
50	Q	22200	20200	18300	16500	13400	10200	8080	6420	5050	3820			
	P	6,25	6,08	5,89	5,69	5,25	4,83	4,29	3,76	3,26	2,79			
HGX34e/315-4 HGX34e/315-4 S HGX34e/315-4 A HGX34e/315-4 S A	30	Q	35900	32700	29800	27000	22100	17600	14100	11100	8590	6550		
		P	4,95	5,00	5,01	4,99	4,86	4,69	4,34	3,96	3,55	3,11		
	40	Q	31300	28500	25900	23500	19200	15100	12000	9420	7260	5500		
P		6,32	6,25	6,16	6,04	5,72	5,33	4,85	4,33	3,80	3,27			
50	Q	26800	24300	22100	20000	16200	12800	10200	7910	6060	4550			
	P	7,63	7,45	7,24	7,02	6,50	5,87	5,25	4,63	3,99	3,37			
HGX34e/380-4 HGX34e/380-4 S HGX34e/380-4 A HGX34e/380-4 S A	30	Q	43500	39600	36000	32700	26700	21600	17500	13900	10900	8310		
		P	6,40	6,35	6,27	6,17	5,93	5,84	5,38	4,91	4,42	3,90		
	40	Q	8000	34600	31400	28400	23200	18700	15100	12000	9320	7140		
P		7,95	7,78	7,59	7,39	6,94	6,71	6,08	5,45	4,82	4,18			
50	Q	32200	29300	26500	24000	19600	15800	12800	10100	7900	6070			
	P	9,52	9,23	8,92	8,60	7,93	7,49	6,69	5,91	5,13	4,36			

- 1
- 2
- 3
- 4
- 5
- 6
- 7
- 8

Relating to 20 °C suction gas temperature, without liquid subcooling

Motor version -S- (more powerful motor)

Supplementary cooling or reduced suction gas temp.

R407C		Performance data								50 Hz 2-pole	
Type	Cond. temp. °C		Cooling capacity \dot{Q}_o [W]					Power consumption P [kW]			
			Evaporation temperature °C								
			12,5	10	7,5	5	0	-5	-10	-15	
HGX34P/255-2 HGX34P/255-2 A	30	Q	52539	47952	43691	39736	32658	26551	21247	16579	
		P	12,07	11,48	10,94	10,44	9,54	8,71	7,90	7,05	
	40	Q	46183	42128	38356	34845	28523	22996	18095	13654	
		P	13,17	12,57	12,01	11,48	10,46	9,45	8,39	7,23	
50	Q	39689	36164	32877	29807	24235	19281	14778			
	P	14,42	13,77	13,15	12,53	11,29	10,01	8,61			
60	Q	32997	29998	27193	24561	19733	15346				
	P	15,72	14,97	14,23	13,48	11,93	10,27				
HGX34P/315-2 S HGX34P/315-2 S A HGX34P/315-2 S A K	30	Q	63241	57821	52726	47944	39278	31740	25246	19713	
		P	13,80	13,29	12,79	12,32	11,40	10,50	9,59	8,65	
	40	Q	55904	51037	46464	42175	34404	27642	21804	16806	
		P	15,40	14,85	14,30	13,76	12,68	11,57	10,40	9,14	
50	Q	48302	44007	39976	36199	29362	23414	18271			
	P	17,11	16,48	15,83	15,18	13,84	12,42	10,89			
60	Q	40621	36918	33448	30202	24339	19243				
	P	18,81	18,04	17,25	16,44	14,75	12,92				
HGX34P/380-2 HGX34P/380-2 A HGX34P/380-2 A K	30	Q	74227	68198	62453	56995	46946	38072	30389	23916	
		P	19,29	18,40	17,54	16,70	15,07	13,53	12,08	10,73	
	40	Q	65658	60233	55067	50164	41150	33212	26367	20634	
		P	21,04	20,07	19,12	18,19	16,38	14,65	13,01	11,45	
50	Q	56631	51863	47330	43034	35163	28269	22369			
	P	22,97	21,88	20,81	19,75	17,68	15,69	13,77			
60	Q			39256	35622	29001	23257				
	P			22,31	21,08	18,68	16,34				

R407C		Performance data								60 Hz 2-pole	
Type	Cond. temp. °C		Cooling capacity \dot{Q}_o [W]					Power consumption P [kW]			
			Evaporation temperature °C								
			12,5	10	7,5	5	0	-5	-10	-15	
HGX34P/315-2 S A K	30	Q	70638	64585	58893	53551	43872	35452	28199	22018	
		P	16,65	16,03	15,43	14,86	13,75	12,66	11,57	10,43	
	40	Q	62443	57007	51899	47108	38429	30875	24354	18772	
		P	18,58	17,91	17,25	16,60	15,30	13,96	12,55	11,03	
50	Q	53952	49155	44652	40433	32797	26153	20408			
	P	20,64	19,87	19,10	18,32	16,70	14,98	13,14			
60	Q	45373	41236	37360	33735	27185	21494				
	P	22,68	21,76	20,81	19,83	17,79	15,59				
HGX34P/380-2 A K	30	Q	82909	76175	69758	63661	52438	42525	33943	26714	
		P	23,26	22,20	21,16	20,14	18,18	16,32	14,57	12,94	
	40	Q	73338	67278	61509	56031	45964	37097	29451	23048	
		P	25,38	24,21	23,07	21,94	19,76	17,68	15,69	13,82	
50	Q	63255	57929	52866	48067	39276	31575	24986			
	P	27,71	26,40	25,10	23,82	21,33	18,92	16,61			
60	Q			43848	39789	32393	25978				
	P			26,91	25,43	22,53	19,71				

Relating to 20 °C suction gas temperature, without liquid subcooling

HG HG Alu	Number of cylinders	Displacement 50 / 60 Hz (1450/1740 rpm)	Electrical data				Weight	Connections ④		Oil charge
			Voltage ①	Max. working current ②	Max. power consumption ②	Starting current (rotor locked)		Discharge line DV	Suction line SV	
Type		m ³ /h		A	kW	A	kg	mm l inch	mm l inch	Ltr.
				Δ / Y		Δ / Y				
HG12P/60-4 S	2	5,40 / 6,40	③	6,8 / 3,9	2,2	40 / 23	48,0	12 l 1/2	16 l 5/8	0,8
HG12P/75-4	2	6,70 / 8,10	③	7,1 / 4,1	2,3	40 / 23	48,0	12 l 1/2	16 l 5/8	0,8
HG12P/75-4 S	2	6,70 / 8,10	③	8,0 / 4,6	2,6	43 / 25	49,0	12 l 1/2	16 l 5/8	0,8
HG12P/90-4	2	8,00 / 9,60	③	8,5 / 4,9	2,8	43 / 25	49,0	12 l 1/2	16 l 5/8	0,8
HG12P/90-4 S	2	8,00 / 9,60	③	8,8 / 5,1	2,9	45 / 26	49,0	12 l 1/2	16 l 5/8	0,8
HG12P/110-4	2	9,40 / 11,30	③	9,2 / 5,3	3,1	43 / 25	49,0	12 l 1/2	16 l 5/8	0,8
HG12P/110-4 S	2	9,40 / 11,30	③	10,6 / 6,1	3,6	45 / 26	49,0	12 l 1/2	16 l 5/8	0,8
HG22e/125-4	2	11,10 / 13,30	③	9,3 / 5,4	3,0	69 / 40	74,0	16 l 5/8	22 l 7/8	1,0
HG22e/125-4 A	2	11,10 / 13,30	③	9,3 / 5,4	3,0	69 / 40	44,0	16 l 5/8	22 l 7/8	1,0
HG22e/125-4 S	2	11,10 / 13,30	③	10,8 / 6,2	3,6	69 / 40	74,0	16 l 5/8	22 l 7/8	1,0
HG22e/125-4 S A	2	11,10 / 13,30	③	10,8 / 6,2	3,6	69 / 40	46,0	16 l 5/8	22 l 7/8	1,0
HG22e/160-4	2	13,70 / 16,40	③	11,1 / 6,4	3,7	69 / 40	74,0	16 l 5/8	22 l 7/8	1,0
HG22e/160-4 A	2	13,70 / 16,40	③	11,1 / 6,4	3,7	69 / 40	46,0	16 l 5/8	22 l 7/8	1,0
HG22e/160-4 S	2	13,70 / 16,40	③	13,1 / 7,6	4,4	87 / 50	76,0	16 l 5/8	22 l 7/8	1,0
HG22e/160-4 S A	2	13,70 / 16,40	③	13,1 / 7,6	4,4	87 / 50	47,0	16 l 5/8	22 l 7/8	1,0
HG22e/190-4	2	16,50 / 19,80	③	13,8 / 8,0	4,8	69 / 40	74,0	16 l 5/8	22 l 7/8	1,0
HG22e/190-4 A	2	16,50 / 19,80	③	13,8 / 8,0	4,8	69 / 40	45,0	16 l 5/8	22 l 7/8	1,0
HG22e/190-4 S	2	16,50 / 19,80	③	16,2 / 9,4	5,6	87 / 50	75,0	16 l 5/8	22 l 7/8	1,0
HG22e/190-4 S A	2	16,50 / 19,80	③	16,2 / 9,4	5,6	87 / 50	47,0	16 l 5/8	22 l 7/8	1,0
HG34e/215-4	4	18,80 / 22,60	③	14,0 / 8,1	4,8	87 / 50	92,0	22 l 7/8	28 l 1 1/8	1,3
HG34e/215-4 A	4	18,80 / 22,60	③	14,0 / 8,1	4,8	87 / 50	55,0	22 l 7/8	28 l 1 1/8	1,3
HG34e/215-4 S	4	18,80 / 22,60	③	18,3 / 10,5	6,0	132 / 76	97,0	22 l 7/8	28 l 1 1/8	1,3
HG34e/215-4 S A	4	18,80 / 22,60	③	18,3 / 10,5	6,0	132 / 76	58,0	22 l 7/8	28 l 1 1/8	1,3
HG34e/255-4	4	22,10 / 26,60	③	17,0 / 9,8	6,0	87 / 50	92,0	22 l 7/8	28 l 1 1/8	1,3
HG34e/255-4 A	4	22,10 / 26,60	③	17,0 / 9,8	6,0	87 / 50	55,0	22 l 7/8	28 l 1 1/8	1,3
HG34e/255-4 S	4	22,10 / 26,60	③	21,1 / 12,2	7,2	132 / 76	96,0	22 l 7/8	28 l 1 1/8	1,3
HG34e/255-4 S A	4	22,10 / 26,60	③	21,1 / 12,2	7,2	132 / 76	58,0	22 l 7/8	28 l 1 1/8	1,3
HG34e/315-4	4	27,30 / 32,80	③	21,1 / 12,2	7,4	111 / 64	94,0	22 l 7/8	28 l 1 1/8	1,3
HG34e/315-4 A	4	27,30 / 32,80	③	21,1 / 12,2	7,4	111 / 64	57,0	22 l 7/8	28 l 1 1/8	1,3
HG34e/315-4 S	4	27,30 / 32,80	③	25,5 / 14,7	8,9	132 / 76	97,0	22 l 7/8	28 l 1 1/8	1,3
HG34e/315-4 S A	4	27,30 / 32,80	③	25,5 / 14,7	8,9	132 / 76	60,0	22 l 7/8	28 l 1 1/8	1,3
HG34e/380-4	4	33,10 / 39,70	③	26,1 / 15,1	9,3	111 / 64	93,0	22 l 7/8	28 l 1 1/8	1,3
HG34e/380-4 A	4	33,10 / 39,70	③	26,1 / 15,1	9,3	111 / 64	56,0	22 l 7/8	28 l 1 1/8	1,3
HG34e/380-4 S	4	33,10 / 39,70	③	31,2 / 18,0	11,1	132 / 76	96,0	22 l 7/8	28 l 1 1/8	1,3
HG34e/380-4 S A	4	33,10 / 39,70	③	31,2 / 18,0	11,1	132 / 76	59,0	22 l 7/8	28 l 1 1/8	1,3

Explanations:

- ① Tolerance ($\pm 10\%$) relates to the mean value of the voltage range. Other voltages and current types on request.
- ② - The specifications for max. power consumption apply for 50Hz operation. For 60Hz operation, the specifications have to be multiplied by the factor 1.2. The max. working current remains unchanged.
- Take account of the max. operating current / max. power consumption when designing contactors, leads and fuses.
Switches: Service category AC3
- ③ 220-240 V Δ / 380-420 V Y - 3 - 50 Hz
265-290 V Δ / 440-480 V Y - 3 - 60 Hz
- ④ For soldering connections

HG 2-pole HG 2-pole Alu	Number of cylinders	Displacement 50 / 60 Hz (1450/1740 rpm)	Electrical data				Weight	Connections ⑤		Oil charge
			Voltage	Max. working current	Max. power consumption	Starting current (rotor locked)		Discharge line DV	Suction line SV	
			①	②	②	A		mm l inch	mm l inch	
Type		m³/h		A	kW	A	kg			Ltr.
				Y		Y				
HGX34P/255-2	4	44,3	③	25,8	16,0	117	95,0	22 l 7/8	35 l 1 3/8	1,3
HGX34P/255-2 A	4	44,3	③	25,8	16,0	117	58,0	22 l 7/8	35 l 1 3/8	1,3
HGX34P/315-2	4	54,7	③	24,3	14,7	117	95,0	22 l 7/8	35 l 1 3/8	1,3
HGX34P/315-2 A	4	54,7	③	24,3	14,7	117	58,0	22 l 7/8	35 l 1 3/8	1,3
HGX34P/315-2 S	4	54,7	③	32,2	19,0	172	103,0	22 l 7/8	35 l 1 3/8	1,3
HGX34P/315-2 S A	4	54,7	③	32,2	19,0	172	68,0	22 l 7/8	35 l 1 3/8	1,3
HGX34P/380-2	4	66,1	③	38,0	23,5	172	102,0	22 l 7/8	35 l 1 3/8	1,3
HGX34P/380-2 A	4	66,1	③	38,0	23,5	172	67,0	22 l 7/8	35 l 1 3/8	1,3

HG 2-pole Alu K	Number of cylinders	Displacement 50 / 60 Hz (1450/1740 rpm)	Electrical data				Weight	Connections ⑤		Oil charge
			Voltage	Max. working current	Max. power consumption	Starting current (rotor locked)		Discharge line DV	Suction line SV	
			①	②	②	A		mm l inch	mm l inch	
Type		m³/h		A	kW	A	kg			Ltr.
				Y		Y				
HGX34P/315-2 A K	4	54,7 / 65,6	④	24,3	14,7	117	58,0	22 l 7/8	35 l 1 3/8	1,3
HGX34P/315-2 S A K	4	54,7 / 65,6	④	32,2	19,0	172	68,0	22 l 7/8	35 l 1 3/8	1,3
HGX34P/380-2 A K	4	66,1 / 79,4	④	38,0	23,5	172	67,0	22 l 7/8	35 l 1 3/8	1,3

Explanations:

- ① Tolerance (± 10%) relates to the mean value of the voltage range. Other voltages and current types on request.
- ② - The specifications for max. power consumption apply for 50Hz operation. For 60Hz operation, the specifications have to be multiplied by the factor 1.2. The max. working current remains unchanged.
- Take account of the max. operating current / max. power consumption when designing contactors, leads and fuses. Switches: Service category AC3
- ③ 380-420 V Y - 3 - 50 Hz
- ④ 380-420 V Y - 3 - 50 Hz
440-480 V Y - 3 - 60 Hz
- ⑤ For soldering connections

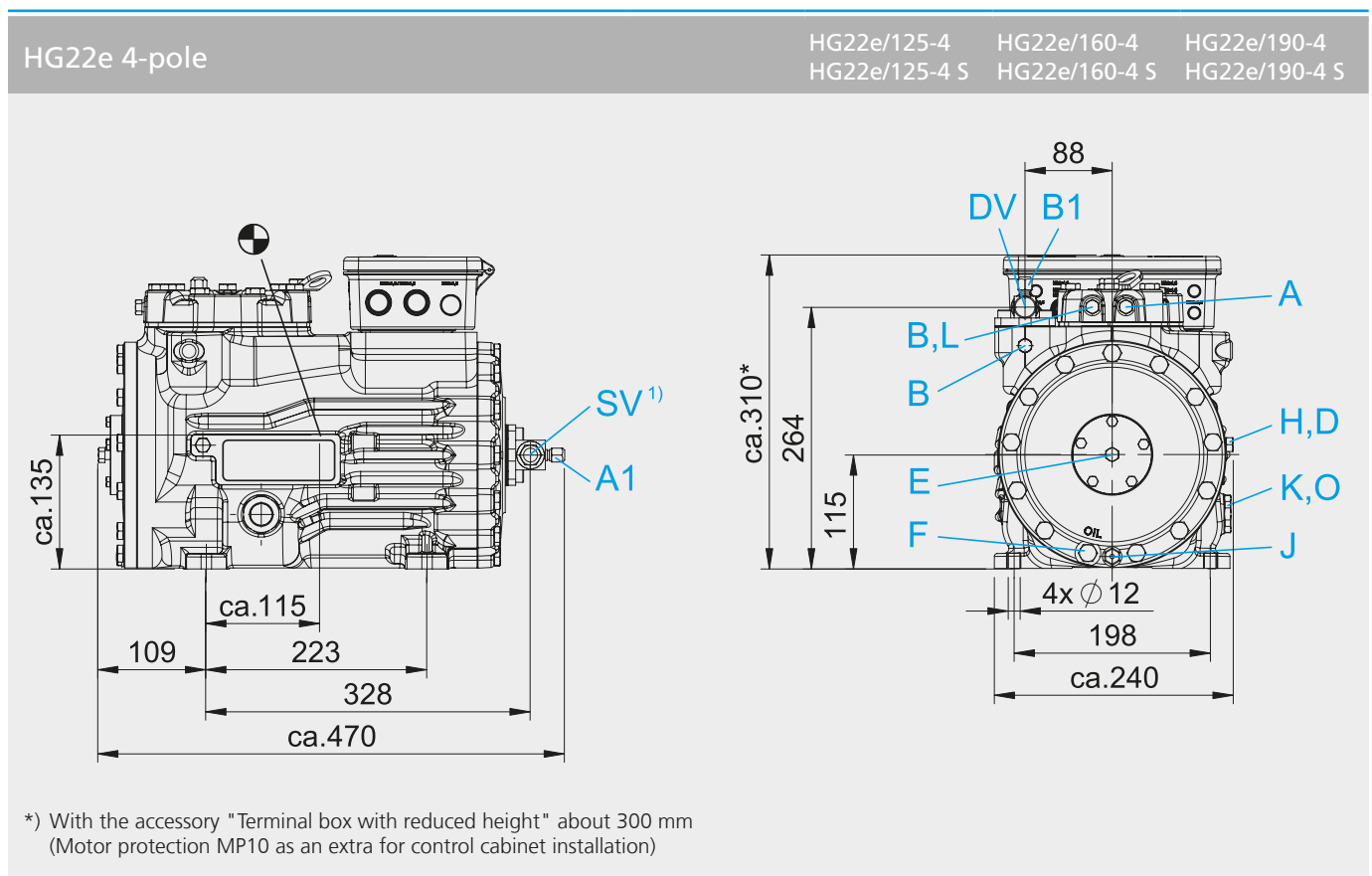
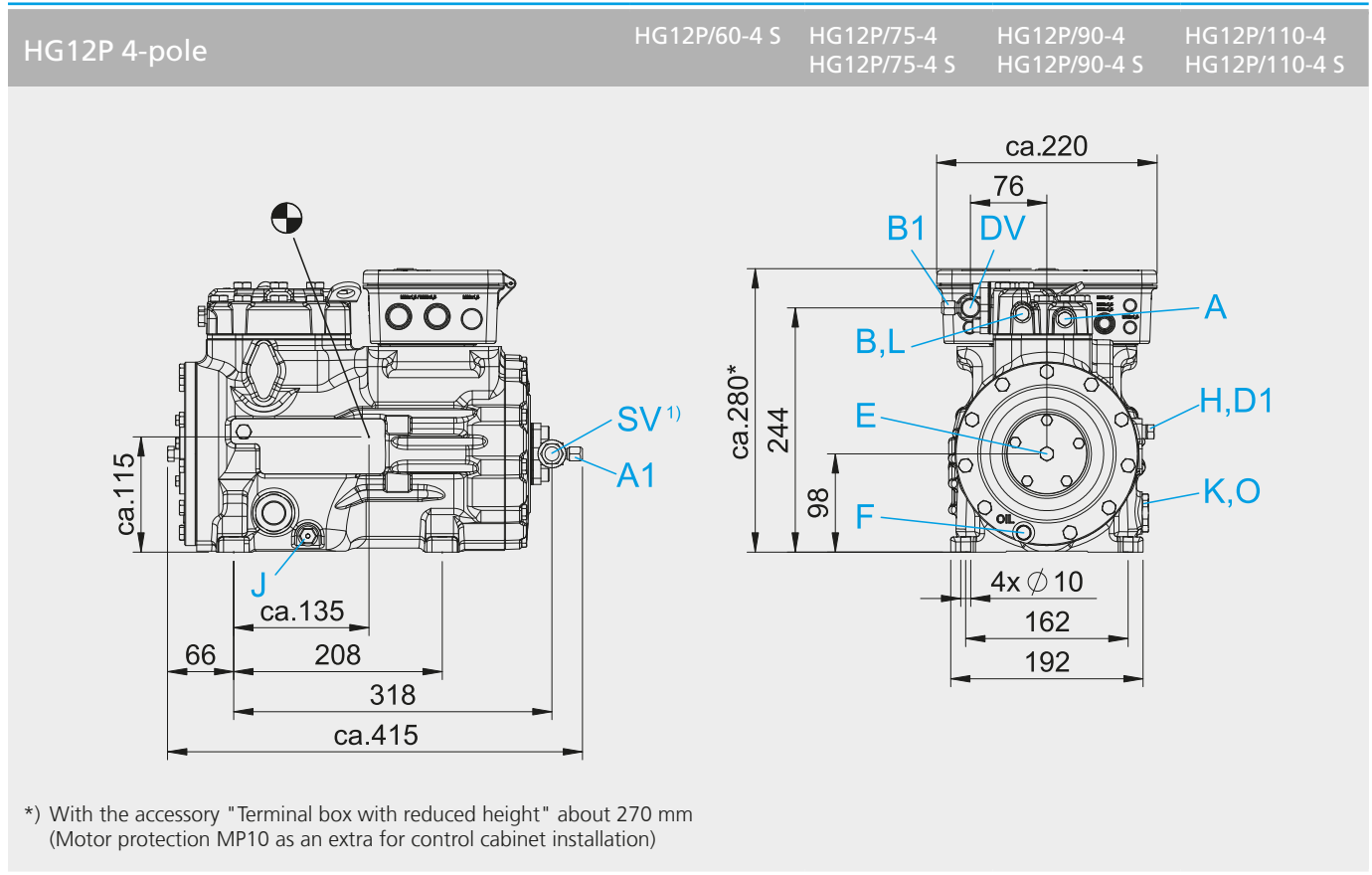

1) SV 90° rotatable
 Centre of gravity

Dimensions in mm
 Connections see page 75

HG22e Aluminium 4-pole

HG22e/125-4 A HG22e/160-4 A HG22e/190-4 A
 HG22e/125-4 S A HG22e/160-4 S A HG22e/190-4 S A

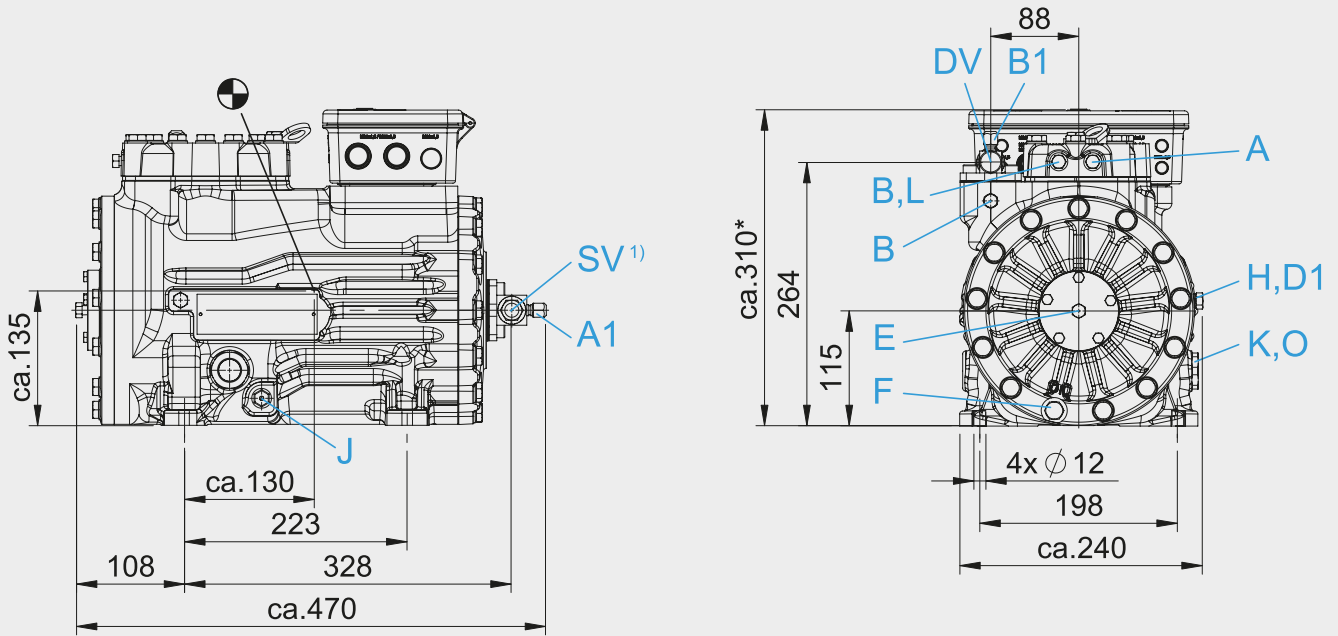

*) With the accessory "Terminal box with reduced height" about 300 mm
 (Motor protection MP10 as an extra for control cabinet installation)

HG34e 4-pole

HG34e/215-4 HG34e/255-4 HG34e/315-4 HG34e/380-4
 HG34e/215-4 S HG34e/255-4 S HG34e/315-4 S HG34e/380-4 S

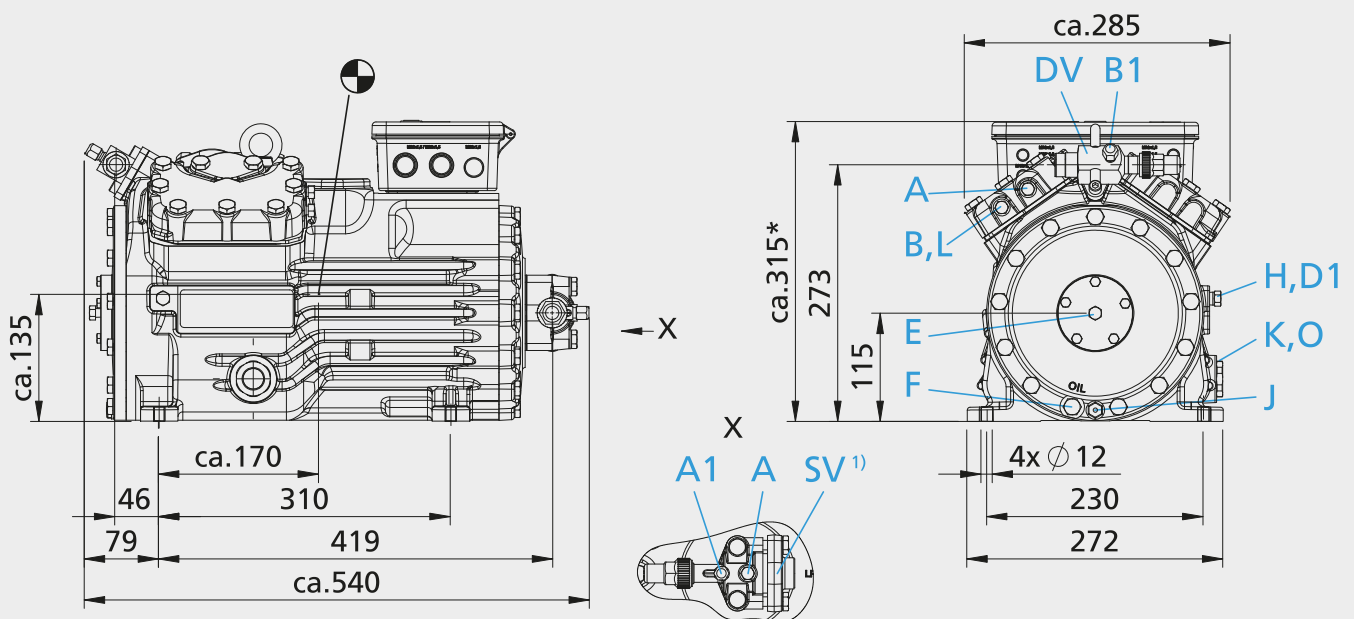

*) With the accessory "Terminal box with reduced height" about 300 mm
 (Motor protection MP10 as an extra for control cabinet installation)

¹⁾ SV 90° rotatable
 Centre of gravity

Dimensions in mm
 Connections see page 75

HG34e Aluminium 4-pole

HG34e/215-4 A HG34e/255-4 A HG34e/315-4 A HG34e/380-4 A
 HG34e/215-4 S A HG34e/255-4 S A HG34e/315-4 S A HG34e/380-4 S A

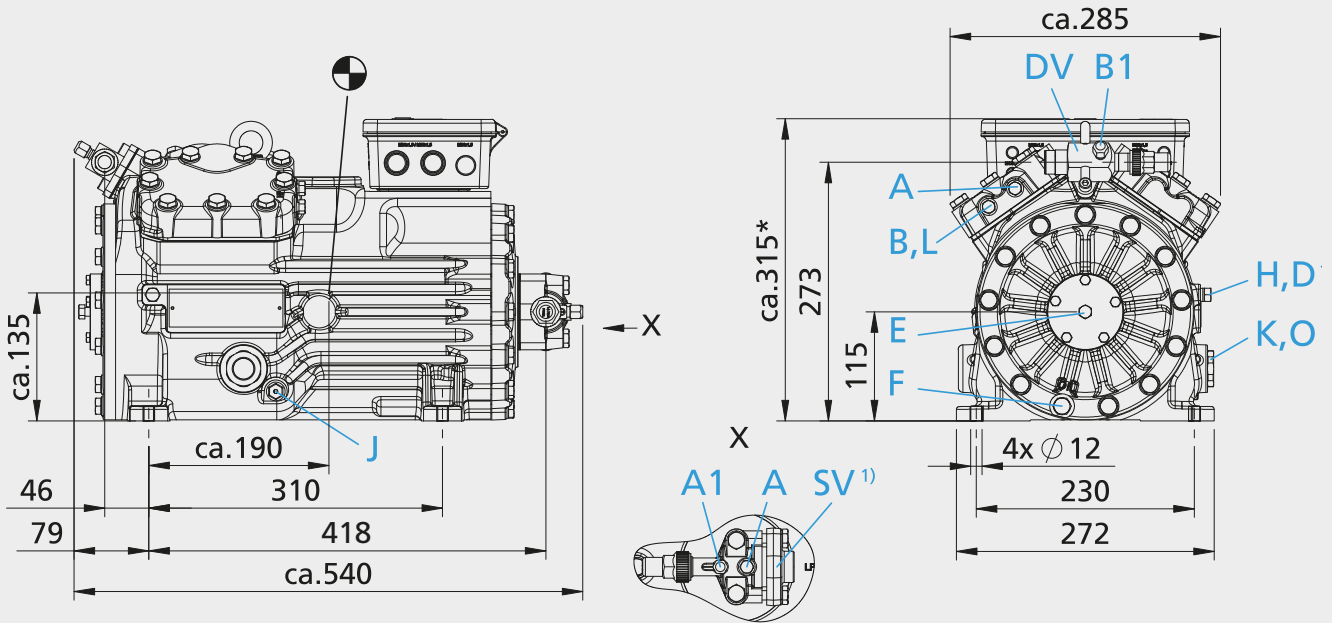

*) With the accessory "Terminal box with reduced height" about 300 mm (Motor protection MP10 as an extra for control cabinet installation)

HGX34P 2-pole

HGX34P/255-2 HGX34P/315-2 HGX34P/380-2
 HGX34P/315-2 S

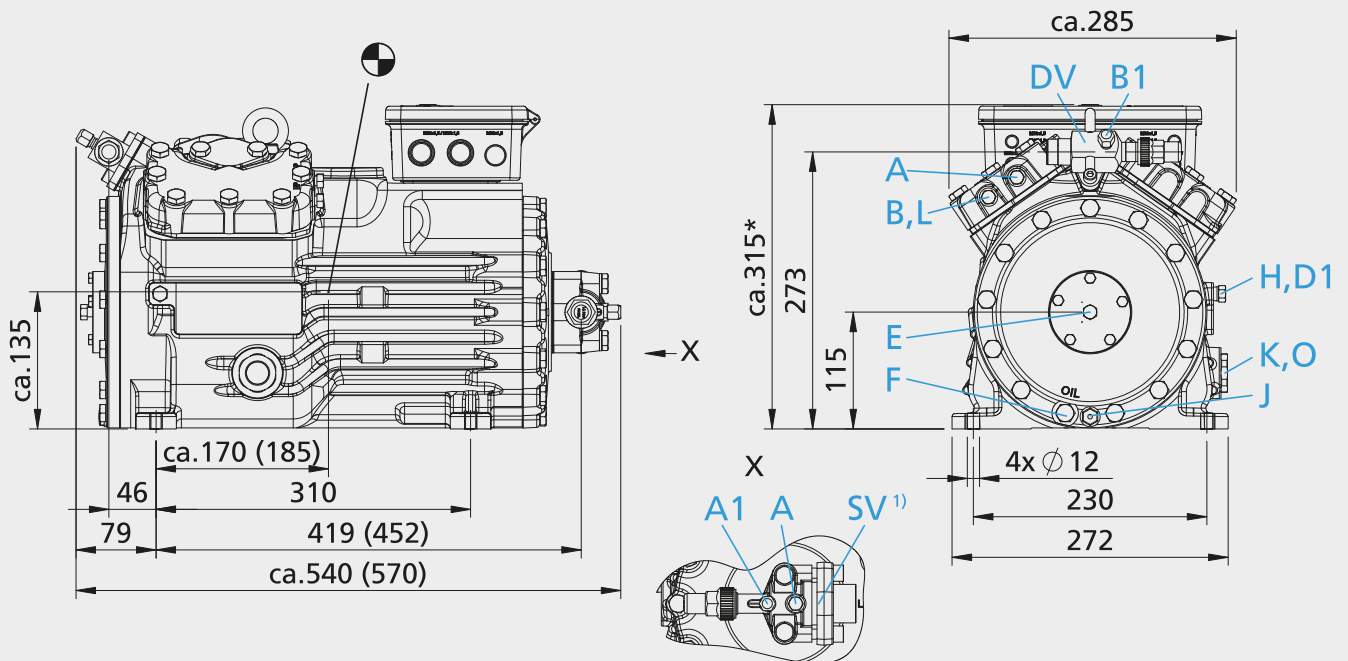

Dimensions in () = HGX34P/315-2 S
 HGX34P/380-2

*) With the accessory "Terminal box with reduced height" about 300 mm (Motor protection MP10 as an extra for control cabinet installation)

1) SV 90° rotatable
 ☉ Centre of gravity

- 1
- 2
- 3
- 4
- 5
- 6
- 7
- 8

HGX34P Aluminium 2-pole

HGX34P/255-2 A

HGX34P/315-2 A

HGX34P/380-2 A

HGX34P/315-2 S A

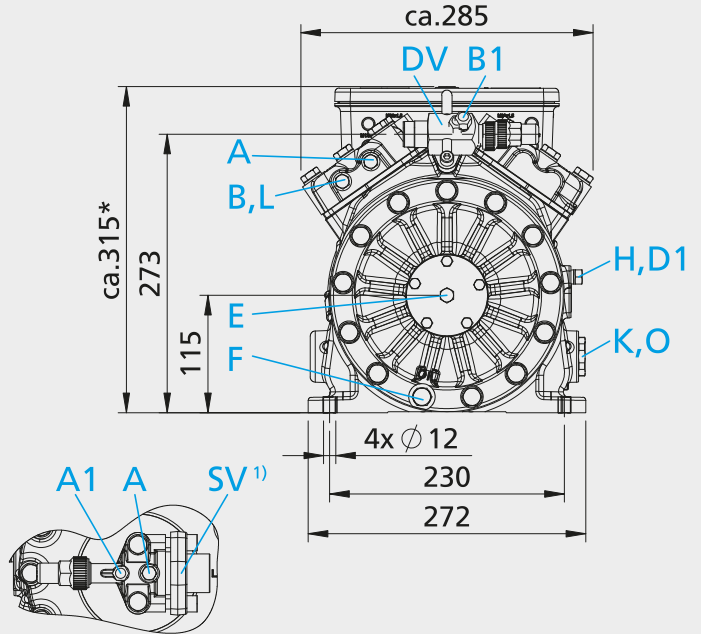
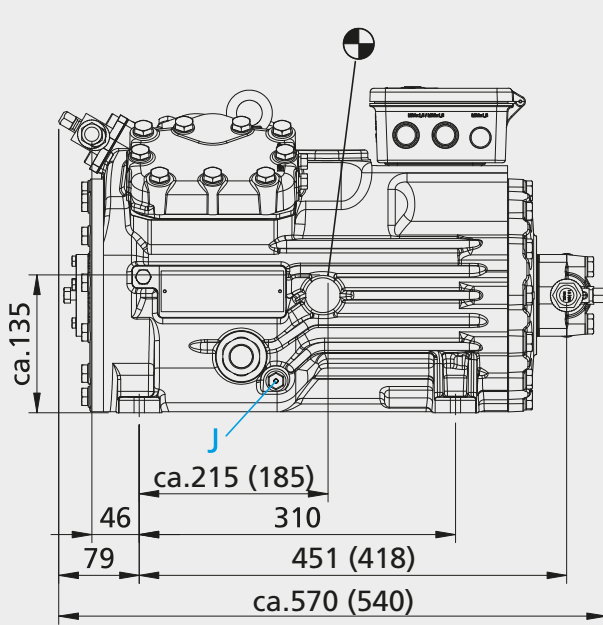

Dimensions in () = HGX34P/255-2 A
HGX34P/315-2 A

*) With the accessory "Terminal box with reduced height" about 300 mm
(Motor protection MP10 as an extra for control cabinet installation)

HGX34P Aluminium 2-pole K

HGX34P/315-2 A K

HGX34P/380-2 A K

HGX34P/315-2 S A K

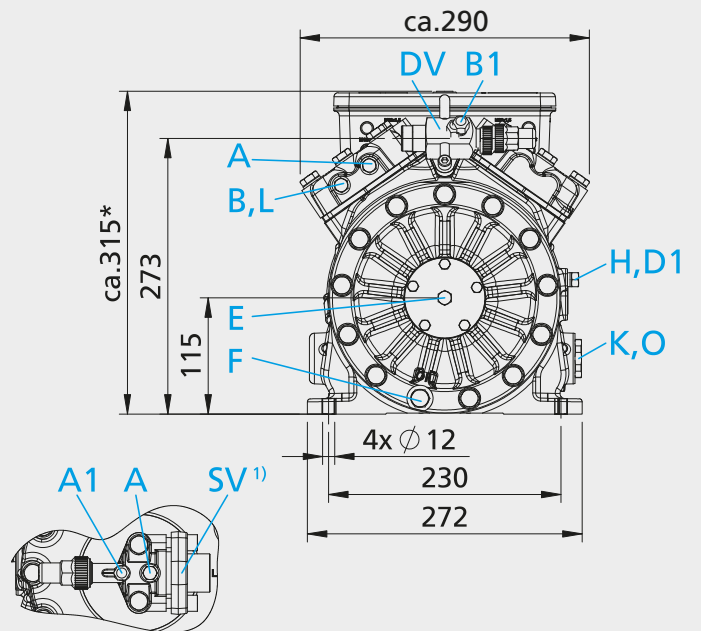
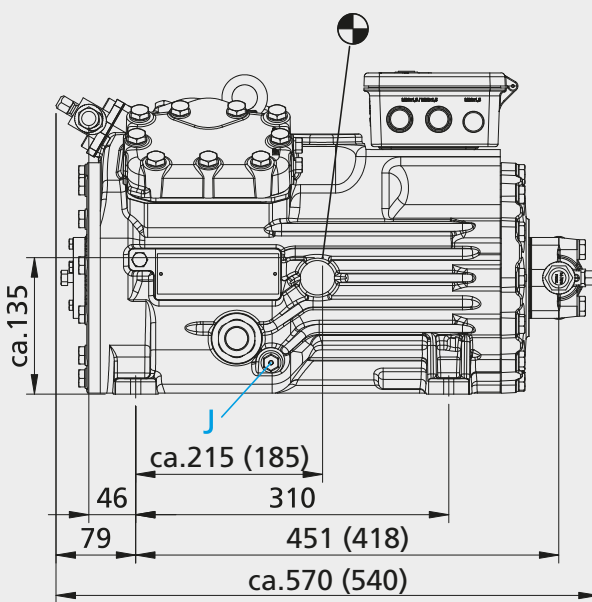

Dimensions in () = HGX34P/255-2 A K
HGX34P/315-2 A K

*) With the accessory "Terminal box with reduced height" about 300 mm
(Motor protection MP10 as an extra for control cabinet installation)

1) SV 90° rotatable
☉ Centre of gravity

Dimensions in mm
Connections see page 75

Connections	HG12P	HG22e ¹⁾	HG34e ¹⁾	HGX34P-2 ¹⁾
SV Suction line DV Discharge line	please refer to technical data page 69 & 70			
A Connection suction side, not lockable	1/8 " NPTF	1/8 " NPTF	1/8 " NPTF	1/8 " NPTF
A1 Connection suction side, lockable	7/16 " UNF	7/16 " UNF	7/16 " UNF	7/16 " UNF
B Connection discharge side, not lockable	1/8 " NPTF	1/8 " NPTF	1/8 " NPTF	1/8 " NPTF
B1 Connection discharge side, lockable	7/16 " UNF	7/16 " UNF	7/16 " UNF	7/16 " UNF
D1 Connection oil return from oil separator	1/4 " NPTF	1/4 " NPTF	1/4 " NPTF	1/4 " NPTF
E Connection oil pressure gauge	1/8 " NPTF	1/8 " NPTF	1/8 " NPTF	1/8 " NPTF
F Oil drain	M 8	M 10	M 10	M 10
H Oil charge plug	1/4 " NPTF	1/4 " NPTF	1/4 " NPTF	1/4 " NPTF
J Connection oil sump heater	Ø 15 mm	Ø 15 mm	Ø 15 mm	Ø 15 mm
K Sight glass	1 1/8 " - 18 UNEF	1 1/8 " - 18 UNEF	1 1/8 " - 18 UNEF	1 1/8 " - 18 UNEF
L Connection thermal protection thermostat	1/8 " NPTF	1/8 " NPTF	1/8 " NPTF	1/8 " NPTF
O Connection oil level regulator	1 1/8 " - 18 UNEF	1 1/8 " - 18 UNEF	1 1/8 " - 18 UNEF	1 1/8 " - 18 UNEF

¹⁾ In cast iron and aluminium version

Dimensions with accessories

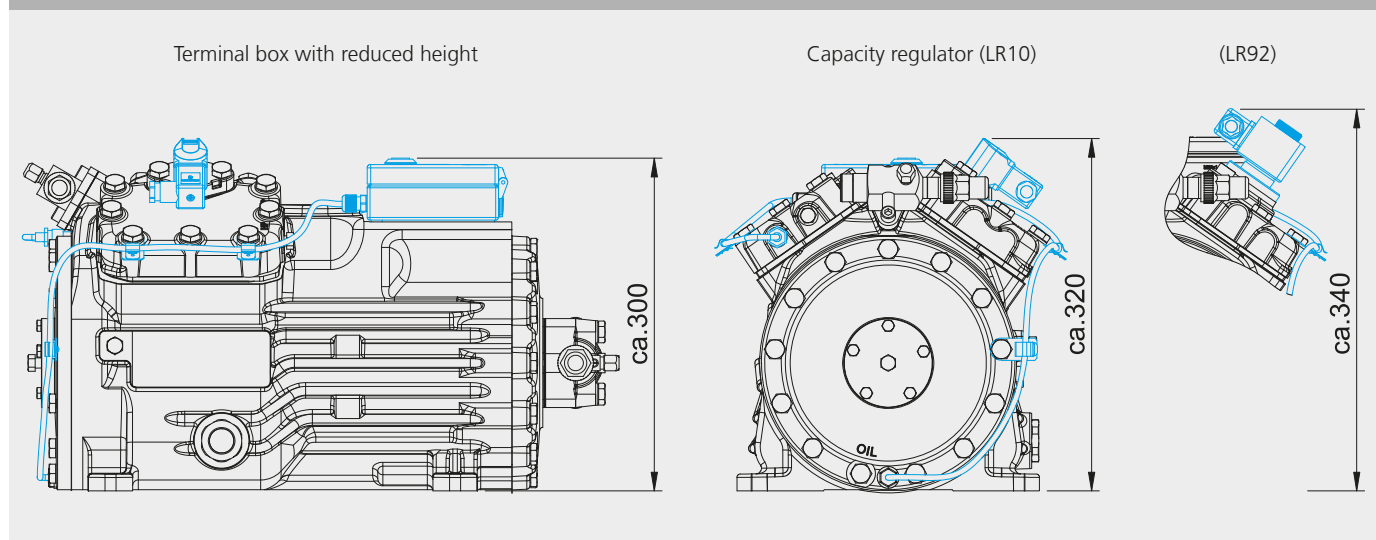

Scope of supply cast iron compressor	HG12P	HG22e	HG34e	HGX34P-2
Semi-hermetic two cylinder reciprocating compressor with drive motor for direct start 220-240 V Δ / 380-420 V Y - 3 - 50 Hz 265-290 V Δ / 440-480 V Y - 3 - 60 Hz Single-section compressor housing with hermetically integrated electric motor	●	●		
Semi-hermetic four cylinder reciprocating compressor with drive motor for direct start 220-240 V Δ / 380-420 V Y - 3 - 50 Hz 265-290 V Δ / 440-480 V Y - 3 - 60 Hz Single-section compressor housing with hermetically integrated electric motor			●	
Semi-hermetic four cylinder reciprocating compressor with drive motor for direct start 380-420 V Y - 3 - 50 Hz Single-section compressor housing with hermetically integrated electric motor				●
Winding protection with PTC resistor sensors and electronic trigger unit Bock MP10 230 V - 1 - 50/60 Hz	●	●	●	●
Oil charge: HG: FUCHS Reniso SP 46 HGX: FUCHS Reniso Triton SE 55	●	●	●	●
Sight glass	●	●	●	●
Suction and discharge line valve	●	●	●	●
Inert gas charge	●	●	●	●

Scope of supply aluminium compressor	HG22e A	HG34e A	HGX34P-2 A	HGX34P-2 A K
Semi-hermetic two cylinder reciprocating compressor with drive motor for direct start 220-240 V Δ / 380-420 V Y - 3 - 50 Hz 265-290 V Δ / 440-480 V Y - 3 - 60 Hz Single-section compressor housing with hermetically integrated electric motor	●			
Semi-hermetic four cylinder reciprocating compressor with drive motor for direct start 220-240 V Δ / 380-420 V Y - 3 - 50 Hz 265-290 V Δ / 440-480 V Y - 3 - 60 Hz Single-section compressor housing with hermetically integrated electric motor		●		
Semi-hermetic four cylinder reciprocating compressor with drive motor for direct start 380-420 V Y - 3 - 50 Hz Single-section compressor housing with hermetically integrated electric motor			●	●
Winding protection with PTC resistor sensors and electronic trigger unit Bock MP10 230 V - 1 - 50/60 Hz	●	●	●	●
Oil charge: HG: FUCHS Reniso SP 46 HGX: FUCHS Reniso Triton SE 55	●	●	●	●
Sight glass	●	●	●	●
Suction and discharge line valve	●	●	●	●
Inert gas charge	●	●	●	●

1

2

3

4

5

6

7

8

Accessories cast iron compressors	HG12P	HG22e	HG34e	HGX34P-2
① Start unloader by means of a Bock ESS (Electronic Soft Start) IP20 (Connection clamps IP00) for installation in switch cabinet		●	●	●
② Capacity regulator 12 V DC, IP65 1 capacity regulator = 50% residual capacity			●	●
Capacity regulator 24 V DC, IP65 1 capacity regulator = 50% residual capacity			●	●
Capacity regulator 24 V - 1 - 50/60 Hz, IP65 1 capacity regulator = 50% residual capacity			●	●
Capacity regulator 110 V - 1 - 50/60 Hz, IP65 1 capacity regulator = 50% residual capacity			●	●
Capacity regulator 230 V - 1 - 50/60 Hz, IP65 1 capacity regulator = 50% residual capacity			●	●
③ Oil sump heater 24 V DC, 80 W, IP66 permanently set version	●	●	●	●
Oil sump heater 110-240 V - 1 - 50/60 Hz, 50-120 W, IP66 PTC heater self-regulating	●	●	●	●
Oil sump heater 400 V - 1 - 50/60 Hz, 80 W, IP66 permanently set version	●	●	●	●
④ Thermal protection thermostat per cylinder cover	● ¹⁾	● ¹⁾	● ¹⁾	● ¹⁾
⑤ Terminal box with reduced height (-15 mm), IP88 (Motor protection MP10 as an extra item for installation in switch cabinet)	●	●	●	●
⑥ MP10 with 24 V DC control voltage	●	●	●	●
MP10 with 110 V - 1 - 50/60 Hz control voltage	●	●	●	●
Special voltage and/or frequency (on request)	●	●	●	●

¹⁾ Installed

Accessories aluminium compressors	HG22e A	HG34e A	HGX34P-2 A	HGX34P-2 A K
① Start unloader by means of a Bock ESS (Electronic Soft Start) IP20 (Connection clamps IP00) for installation in switch cabinet	●	●	●	●
② Capacity regulator 12 V DC, IP65 1 capacity regulator = 50% residual capacity		●	●	●
Capacity regulator 24 V DC, IP65 1 capacity regulator = 50% residual capacity		●	●	●
Capacity regulator 24 V - 1 - 50/60 Hz, IP65 1 capacity regulator = 50% residual capacity		●	●	●
Capacity regulator 110 V - 1 - 50/60 Hz, IP65 1 capacity regulator = 50% residual capacity		●	●	●
Capacity regulator 230 V - 1 - 50/60 Hz, IP65 1 capacity regulator = 50% residual capacity		●	●	●
③ Oil sump heater 24 V DC, 80 W, IP66 permanently set version	●	●	●	●
Oil sump heater 110-240 V - 1 - 50/60 Hz, 50-120 W, IP66 PTC heater self-regulating	●	●	●	●
Oil sump heater 400 V - 1 - 50/60 Hz, 80 W, IP66 permanently set version	●	●	●	●
④ Thermal protection thermostat per cylinder cover	● ¹⁾	● ¹⁾	● ¹⁾	● ¹⁾
⑤ Terminal box with reduced height (-15 mm), IP66 (Motor protection MP10 as an extra item for installation in switch cabinet)	●	●	●	●
⑥ MP10 with 24 V DC control voltage	●	●	●	●
MP10 with 110 V - 1 - 50/60 Hz control voltage	●	●	●	●
Special voltage and/or frequency (on request)	●	●	●	●
⑦ Kit for silent block		●	●	●

¹⁾ Installed

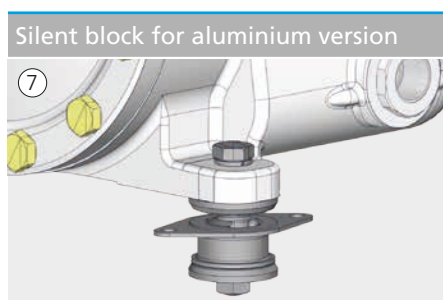
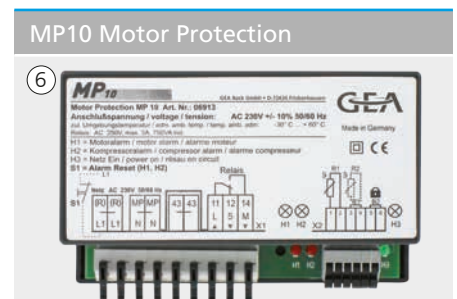
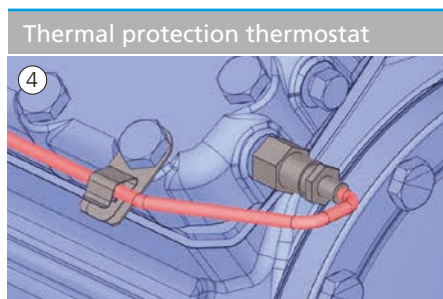
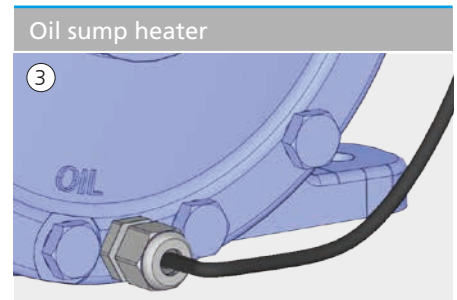
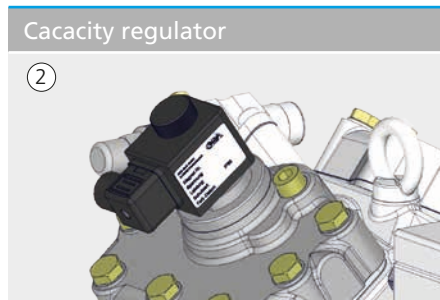

1
2
3
4
5
6
7
8





Semi-hermetic Compressors for R407C up to 35 bar

At a glance	82
Operating limits and performance data	83
Technical data	85
Dimensions and connections	86
Scope of supply	88
Accessories	89

Semi-hermetic compressors for air-conditioning applications with R407C

Based on our current semi-hermetic product range, with its outstanding advantages and features, there is now a compressor series available for the use with the refrigerant R407C with expanded fields of application.

Those compressors are especially suited for the application in mobile air-conditioning systems, such as railway air-conditioning.

Condensing pressures of up to 35 bar possible (approx. 74 °C condensing temperature).

Special features

To ensure the reliable operation of the refrigerant R407C in countries with high ambient temperatures of up to 50°C, Bock compressors for R407C are approved for a maximum operating pressure of 35 bar.

This corresponds to a condensing temperature of approx. 74 °C and opens up completely new possibilities for the use of this refrigerant.

To guarantee the highest possible operational safety, GEA Bock uses its long experience with special compressors for other high pressure refrigerants that are already used thousands of times in many mobile and stationary applications.

Available models	Displacement 50 Hz (1.450 rpm)
HGX34e/215-4 S R407C	18,8 m³/h
HGX34e/255-4 S R407C	22,1 m³/h
HGX34e/315-4 S R407C	27,3 m³/h
HGX34e/380-4 S R407C	33,1 m³/h

The refrigerant R407C

Besides R407C, R410A is also considered a long-term replacement refrigerant for R22. In addition, it is an alternative to R134a.

Suitable refrigeration oils are ester oils, such as e.g. Fuchs Reniso SE55.

Type key

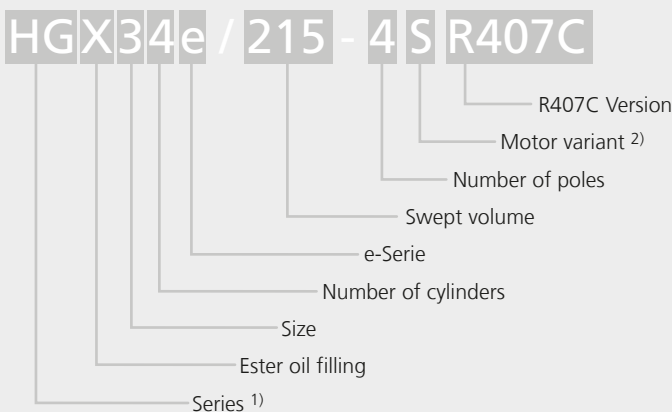

- 1) HG = Hermetic Gas-cooled (suction gas-cooled)
- 2) S = More powerful motor e.g. air-conditioning systems

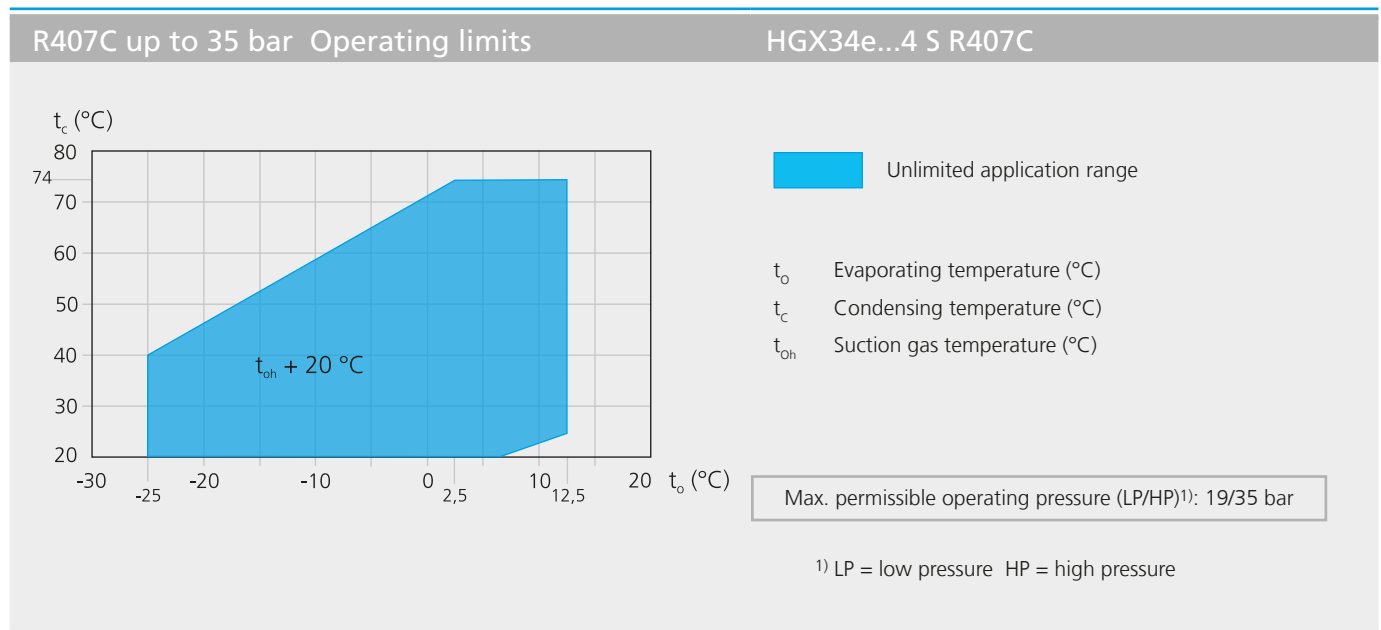

R407C up to 35 bar Notes	
<p>Operating limits</p> <p>Compressor operation is possible within the limits shown on the application diagrams. Compressor application limits should not be chosen for design purposes or continuous operation.</p> <p>Restrictions to the operating limits may occur when using a frequency converter.</p> <p>Restrictions to the operating limits may occur when using a capacity regulator.</p>	<p>Performance data</p> <p>The performance data for R407C are based on the european standard EN 12900 at 50 Hz supply frequency. This signifies 20 °C suction gas temperatures without liquid subcooling.</p> <p>The evaporating- and condensing temperautres are based on the dew point values (saturated vapour conditions).</p> <p>This results in significant differences compared to specifications with liquid undercooling and/or suction gas temperatures.</p> <p>Conversion factor for 60 Hz = 1,2</p> <p>Performance data for other operating points, see GEA Bock software.</p>

- 1
- 2
- 3
- 4
- 5
- 6
- 7
- 8

R407C up to 35 bar			Performance data					50 Hz 4-pole
Type	Cond. temp. °C		Cooling capacity \dot{Q}_o [W]			Power consumption P [kW]		
			Evaporation temperature °C					
			12,5	10	7,5	5	0	
HGX34e/215-4 S R407C	30	Q	25600	23300	21100	19100	15600	
		P	3,45	3,49	3,50	3,48	3,39	
	40	Q	22400	20300	18400	16600	13400	
		P	4,38	4,33	4,26	4,17	3,94	
	50	Q	19100	17300	15600	14100	11300	
		P	5,19	5,06	4,91	4,75	4,39	
60	Q	15900	14300	12900	11500	9190		
	P	5,90	5,69	5,47	5,24	4,75		
70	Q	12500	11200	9960	8880	7020		
	P	6,51	6,23	5,94	5,64	5,03		
HGX34e/255-4 S R407C	30	Q	29600	27000	24600	22300	18300	
		P	4,30	4,30	4,28	4,23	4,08	
	40	Q	26000	23600	21500	19500	15800	
		P	5,33	5,24	5,13	5,00	4,71	
	50	Q	22200	20200	18300	16500	13400	
		P	6,25	6,08	5,89	5,69	5,25	
60	Q	18400	16700	15100	13600	11000		
	P	7,08	6,83	6,57	6,30	5,74		
70	Q	14800	13400	12100	10900	8780		
	P	7,85	7,53	7,20	6,87	6,20		
HGX34e/315-4 S R407C	30	Q	35900	32700	29800	27000	22100	
		P	4,95	5,00	5,01	4,99	4,86	
	40	Q	31300	28500	25900	23500	19200	
		P	6,32	6,25	6,16	6,04	5,72	
	50	Q	26800	24300	22100	20000	16200	
		P	7,63	7,45	7,24	7,02	6,50	
60	Q	22200	20100	18200	16500	13400		
	P	8,76	8,47	8,15	7,81	7,10		
70	Q	17600	16000	14400	13000	10600		
	P	9,61	9,19	8,76	8,31	7,39		
HGX34e/380-4 S R407C	30	Q	43500	39600	36000	32700	26700	
		P	6,40	6,35	6,27	6,17	5,93	
	40	Q	38000	34600	31400	28400	23200	
		P	7,95	7,78	7,59	7,39	6,94	
	50	Q	32200	29300	26500	24000	19600	
		P	9,52	9,23	8,92	8,60	7,93	
60	Q	26500	24000	21800	19700	16100		
	P	10,90	10,40	10,00	9,58	8,67		
70	Q	21100	19200	17400	15800	13100		
	P	11,80	11,20	10,70	10,10	8,94		

Relating to 20 °C suction gas temperature,
without liquid subcooling

HG R407C Type	Number of cylinders	Displacement 50 / 60 Hz (1450/1740 rpm) m ³ /h	Electrical data				Weight kg	Connections ④		Oil charge Ltr.
			Voltage ①	Max. working current ② A Y	Max. power consumption ② kW	Starting current (rotor locked) A Y		Discharge line DV mm l inch	Suction line SV mm l inch	
HGX34e/215-4 S R407C	4	18,80 / 22,60	③	20,1 / 11,6	6,8	132 / 76	97,0	22 7/8	28 1 1/8	1,3
HGX34e/255-4 S R407C	4	22,10 / 26,60	③	23,7 / 13,7	8,2	132 / 76	96,0	22 7/8	28 1 1/8	1,3
HGX34e/315-4 S R407C	4	27,30 / 32,80	③	28,1 / 16,2	9,9	132 / 76	97,0	22 7/8	28 1 1/8	1,3
HGX34e/380-4 S R407C	4	33,10 / 39,70	③	33,8 / 19,5	12,1	132 / 76	96,0	22 7/8	28 1 1/8	1,3

Explanations:

- ① Tolerance ($\pm 10\%$) relates to the mean value of the voltage range. Other voltages and current types on request.
- ② - The specifications for max. power consumption apply for 50Hz operation. For 60Hz operation, the specifications have to be multiplied by the factor 1.2. The max. working current remains unchanged.
- Take account of the max. operating current / max. power consumption when designing contactors, leads and fuses. Switches: Service category AC3
- ③ 220-240 V Δ / 380-420 V Y - 3 - 50 Hz
265-290 V Δ / 440-480 V Y - 3 - 60 Hz
- ④ For soldering connections

1
2
3
4
5
6
7
8

HGX34e R407C

HGX34e/215-4 S R407C
HGX34e/255-4 S R407C

HGX34e/315-4 S R407C
HGX34e/380-4 S R407C

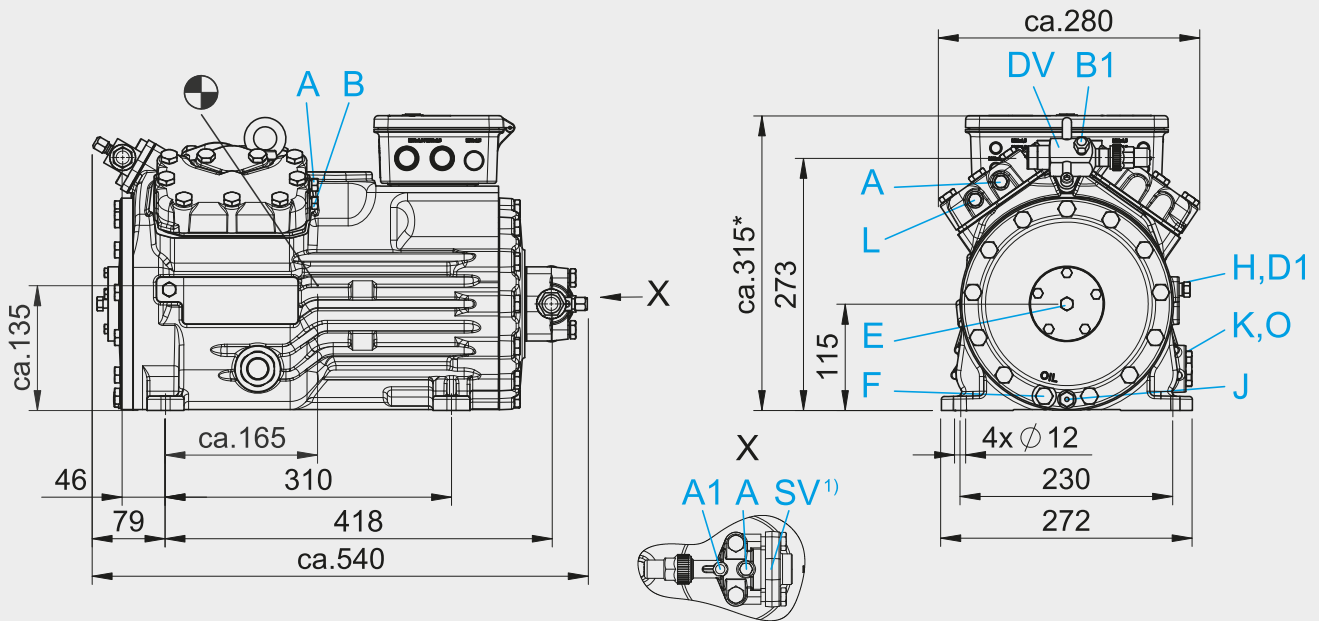

*) With the accessory "Terminal box with reduced height" about 300 mm
(Motor protection MP10 as an extra for control cabinet installation)

Connections		
SV	Suction line	please refer to technical data page 85
DV	Discharge line	
A	Connection suction side, not lockable	1/8" NPTF
A1	Connection suction side, lockable	7/16" UNF
B	Connection discharge side, not lockable	1/8" NPTF
B1	Connection discharge side, lockable	7/16" UNF
D1	Connection oil return from oil separator	1/4" NPTF
E	Connection oil pressure gauge	1/8" NPTF
F	Oil drain	M 10
H	Oil charge plug	1/4" NPTF
J	Connection oil sump heater	Ø 15 mm
K	Sight glass	1 1/8" - 18 UNEF
L	Connection thermal protection thermostat	1/8" NPTF
O	Connection oil level regulator	1 1/8" - 18 UNEF

1

2

3

4

5

6

7

8

Scope of supply

Semi-hermetic four cylinder reciprocating compressor with drive motor for direct start

220-240 V Δ / 380-420 V Y - 3 - 50 Hz

265-290 V Δ / 440-480 V Y - 3 - 60 Hz

Single-section compressor housing with hermetically integrated electric motor

Winding protection with PTC resistor sensors and electronic trigger unit Bock MP10 230 V - 1 - 50/60 Hz

Oil charge

HGX: FUCHS Reniso Triton SE 55

Sight glass

Suction and discharge line valve

Inert gas charge

Accessories	
①	Start unloader by means of a Bock ESS (Electronic Soft Start) IP20, (Connection clamps IP00) for installation in switch cabinet
②	Capacity regulator 12 V DC, IP65 1 capacity regulator = 50 % residual capacity
	Capacity regulator 24 V DC, IP65 1 capacity regulator = 50 % residual capacity
	Capacity regulator 24 V - 1 - 50/60 Hz, IP65 1 capacity regulator = 50 % residual capacity
	Capacity regulator 110 V - 1 - 50/60 Hz, IP65 1 capacity regulator = 50 % residual capacity
	Capacity regulator 230 V - 1 - 50/60 Hz, IP65 1 capacity regulator = 50 % residual capacity
③	Oil sump heater 24 V DC, 80 W, IP66 permanently set version
	Oil sump heater 110-240 V - 1 - 50/60 Hz, 50-120 W, IP66 PTC heater self-regulating
	Oil sump heater 400 V - 1 - 50/60 Hz, 80 W, IP66 permanently set version
④	Thermal protection thermostat per cylinder cover ¹⁾
⑤	Terminal box with reduced height (-15 mm), (Motor protection MP10 as an extra item for installation in switch cabinet)
⑥	MP10 with 24 V DC control voltage MP10 with 110 V - 1 - 50/60 Hz control voltage Special voltage and/or frequency (on request)

¹⁾ Installed

- 1
- 2
- 3
- 4
- 5
- 6
- 7
- 8

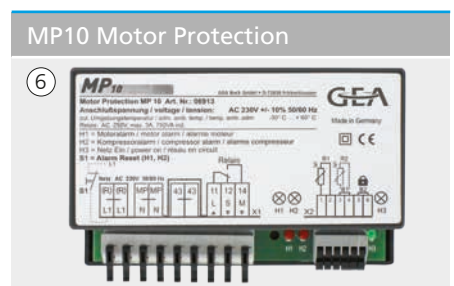
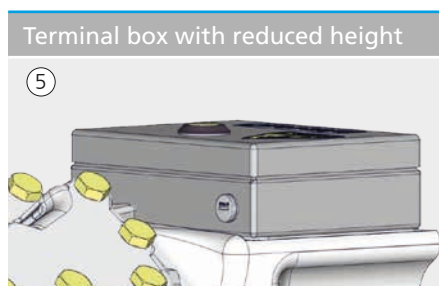
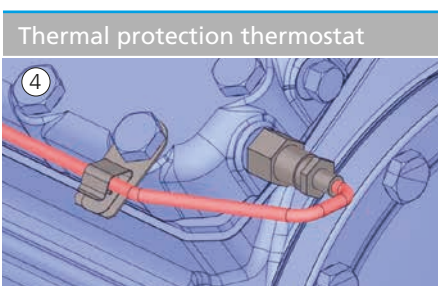
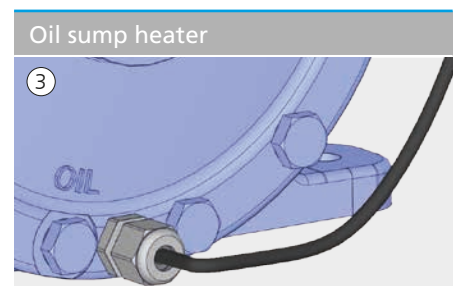
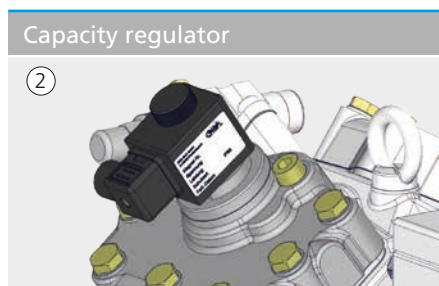

Because you're never done learning - GEA Bock training and workshops on compressors

Many years ago, GEA Bock intensified its commitment in the area of customer training.

And so we offer a comprehensive array of attractive training events, from two-day practitioners' workshops in Frickenhausen to afterwork workshops throughout Germany. Regardless of the type of training you are interested in.

Three things are characteristic of all GEA Bock training:

- The captivating way that the training director carries out the events
- The strong practice orientation of the training events, and
- The fact that all training events from Bock are offered as a free service

Overview of training events offered:

- GEA Bock Practitioners' Workshop
- Training tailored to your individual needs
- Training for your entire staff
- Training on your premises

For additional questions or advice, please contact our training director:

Peter Spies
Telephone +49 (7022) 945 4-157
Fax +49 (7022) 945 4-137
Email: Peter.Spies@gea.com





- 1
- 2
- 3
- 4
- 5
- 6
- 7



We live our values.

Excellence • Passion • Integrity • Responsibility • GEA-versity

GEA Group is a global engineering company with multi-billion euro sales and operations in more than 50 countries. Founded in 1881, the company is one of the largest providers of innovative equipment and process technology. GEA Group is listed in the STOXX® Europe 600 index.

GEA Refrigeration Technologies

GEA Bock GmbH

Benzstraße 7, 72636 Frickenhausen, Germany
Phone: +49 7022 9454-0, Fax: +49 7022 9454-137
bock@gea.com, www.bock.de, www.gea.com